

Super II Economy VS™

Variable Speed Pump

Owner's Manual

To prevent potential injury and to avoid unnecessary service calls read this manual carefully and completely.

SAVE THIS INSTRUCTION MANUAL

Hayward Pool Products (Australia) Pty Ltd.
Melbourne-Sydney-Brisbane-Perth
Email: sales@hayward-pool.com.au | Website: www.hayward-pool.com.au
PO Box 4384 | Dandenong South VIC 3164
ABN 66 083 413 414
Sales Contact Ph: 1300POOLS1 Fax: 1300POOLS2

USE ONLY HAYWARD® GENUINE REPLACEMENT PARTS

30-LITINSB0020

IMPORTANT SAFETY INSTRUCTIONS

Before installing or servicing this electrical equipment, turn power supply OFF





WARNING

Read and follow all instructions in this owner's manual and on the equipment. Failure to follow instructions can cause severe injury and/or death

 **WARNING** - This manual contains important information about the installation, operation, and safe use of this pump that must be transferred through to the end user of this product.

 **WARNING** - This product should be installed and serviced only by a qualified professional.

 **WARNING** - All electrical wiring **MUST** be performed by a qualified electrical contractor, and must conform to local electrical regulations and the Latest Edition AS/NZS 3000 Wiring Rules.

 **WARNING** - This appliance is not intended for use by persons (including children) with reduced physical, sensory or mental capabilities, or lack of experience and knowledge, unless they have been given supervision or instruction concerning use of the appliance by a person responsible for their safety. **CHILDREN SHOULD BE SUPERVISED TO ENSURE THAT THEY DO NOT PLAY WITH THE APPLIANCE.**

 **CAUTION** - This pump is intended for use on permanently installed swimming pools and may also be used with hot tubs and spas if so marked. Do NOT use with storable pools. A permanently installed pool is constructed in or on the ground or in a building such that it cannot be readily disassembled for storage. A storable pool is constructed so that it is capable of being readily disassembled for storage and reassembled to its original integrity. Though this product is designed for outdoor use, it is strongly advised to protect the electrical components from the weather. Select a well-drained area, one that will not flood when it rains. It requires free circulation of air for cooling. Do not install in a damp or non-ventilated location. If installed within an outer enclosure or beneath the skirt of a hot tub or spa, adequate ventilation and free circulation of air must be provided to prevent overheating of the motor.

 **WARNING** - Pool and spa components have a finite life. All components should be inspected frequently and replaced at least every ten years, or if found to be damaged, broken, cracked, missing, or not securely attached.



 **WARNING - Risk of Electric Shock.** All electrical wiring must be performed by a qualified electrical contractor, and must conform to Local/State/Federal electrical regulations and the Latest Edition AS/NZ 3000 Wiring Rules. **All electrical circuits must be supplied through a Residual Current Device - RCD (Safety Switch), with a residual operating current of 30 mA.** Hazardous voltage can shock, burn and cause death or serious property damage. To reduce the risk of electric shock, do NOT use an extension cord to connect unit to the electricity supply.

 **WARNING** - To reduce the risk of electric shock replace damaged wiring immediately. Locate the power cord so that it cannot be damaged by lawn mowers, hedge trimmers and other equipment.

 **WARNING** - Never operate the circulation system at more than (50 PSI) 344 kPa maximum.

 **WARNING - Automatic Restart.** The pump motor is automatically protected from overload and overheating. If such an error occurs the controller will automatically try to restart the pump. If a power failure occurs while the pump is running, it will automatically restart once the power has been restored.

IMPORTANT SAFETY INSTRUCTIONS

Before installing or servicing this electrical equipment, turn power supply OFF

⚠ WARNING – Hazardous Pressure. Pool and spa water circulation systems operate under hazardous pressure during start-up, normal operation, and after pump shut-off. Stand clear of circulation system equipment during pump start-up. Failure to follow safety and operation instructions could result in violent separation of the pump housing and cover due to pressure in the system. This separation could cause property damage, severe personal injury, or death. Before servicing the pool and spa water circulation system, all system and pump controls must be in the off position and the Filter Manual Air Relief Valve must be in the open position. Before starting the system pump, all valves must be set in a position to allow system water to return back to the pool. Do not change the Filter Control Valve position while the system pump is running. Before starting the system pump, fully open the Filter Manual Air Relief Valve. Do not close the Filter Manual Air Relief valve until all the air is expelled and a steady stream of water is discharged from the valve. All suction and discharge valves **MUST BE OPEN** when starting the circulation system. Failure to do so could result in severe personal injury and/or property damage.



⚠ WARNING – Separation Hazard. Failure to follow safety and operation instructions could result in violent separation of pump components. Strainer cover must be properly secured to pump housing with the strainer cover lock ring. Before servicing pool and spa circulation system, all system and pump controls must be in off position and the Filter Manual Air Relief Valve must be in open position. Do not operate pool and spa circulation system if system components are not assembled properly, damaged, or missing. Do not operate pool and spa circulation system unless the Filter Air Relief Valve body is in locked position within the filter upper body. All suction and discharge valves **MUST BE OPEN** when starting the circulation system. Failure to do so could result in severe personal injury and/or property damage.



⚠ WARNING – Suction Entrapment Hazard. The force from suction in suction outlets and/or suction outlet covers which are damaged, broken, cracked, missing, or unsecured, can cause severe injury and/or death due to the following entrapment hazards:



Hair Entrapment - Hair can become entangled in suction outlet cover.



Limb Entrapment - A limb inserted into an opening of a suction outlet sump or suction outlet cover that is damaged, broken, cracked, missing, or not securely attached, can result in a mechanical bind or swelling of the limb.



Body Suction Entrapment - A differential pressure applied to a large portion of the body or limbs can result in an entrapment.



Evisceration/Disembowelment - A negative pressure applied directly to the intestines through an unprotected suction outlet sump or suction outlet cover which is damaged, broken, cracked, missing, or unsecured, can result in evisceration/disembowelment.



Mechanical Entrapment - There is potential for jewelry, swimsuits, hair decorations, fingers, toes, or knuckles, to be caught in an opening of a suction outlet cover resulting in mechanical entrapment.

⚠ WARNING – To Reduce the risk of Entrapment Hazards:

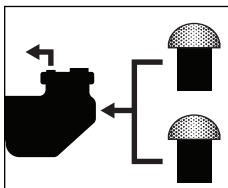

- » When outlets are small enough to be blocked by a person, a minimum of two functioning suction outlets per pump must be installed. Suction outlets in the same plane (i.e. floor or wall), must be installed a minimum of 0.91 metres or three feet (3') apart, as measured from near point to near point to avoid dual blockage by a user.
- » Dual suction fittings shall not be located on seating areas or on the backrest for such seating areas.
- » Never use pool or spa if any suction outlet component is damaged, broken, cracked, missing, or not securely attached.
- » Replace damaged, broken, cracked, missing, or not securely attached suction outlet components immediately.
- » In addition to installing two or more suction outlets per pump, follow all National, State and Local regulations and AS 1926.3 Latest Edition.
- » Installation of a vacuum release or vent system, which relieves entrapping suction, is recommended.

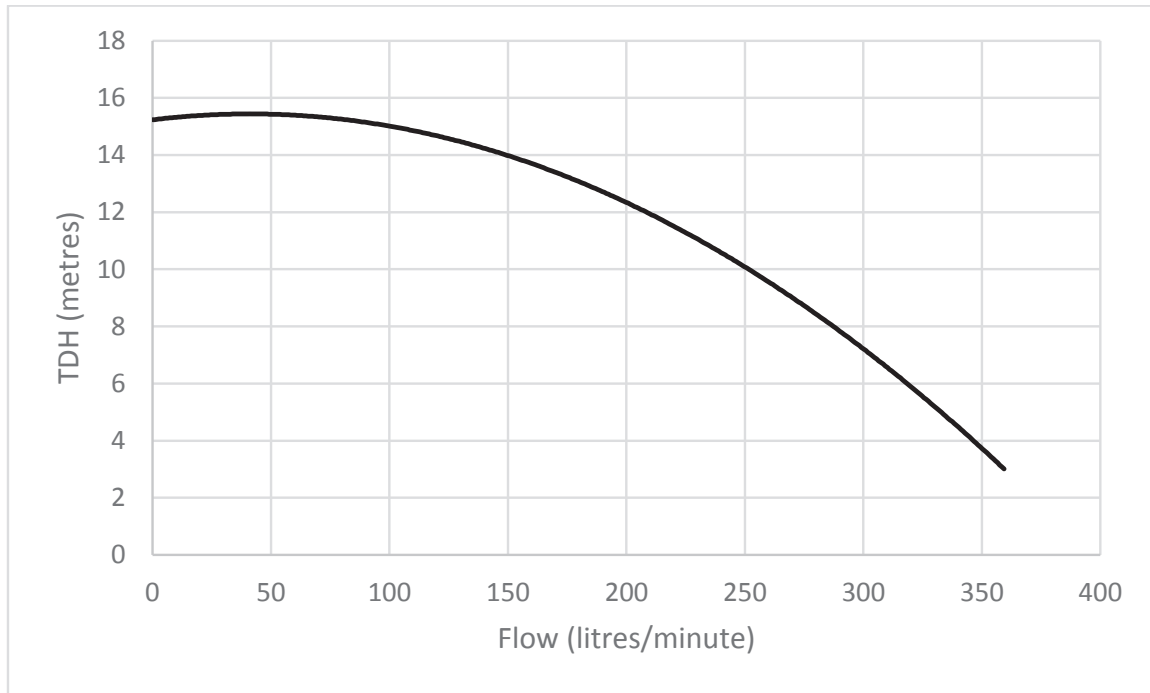

MAXIMUM TOTAL HEAD

Model	Maximum Total Head	Input kW	Input Amps	Noise dBA	Weight (kg)	Ingress Protection
SP3011DIVS	15.5m / 152kPa	0.93kW	5.85	< 70	11	IPX5

INTRODUCTION

This manual contains information for the proper installation and operation of the Hayward Super II Economy Variable Speed Pump. The instructions in this manual **MUST** be followed precisely. Failure to install according to defined instructions will void warranty.

Product Dimensions

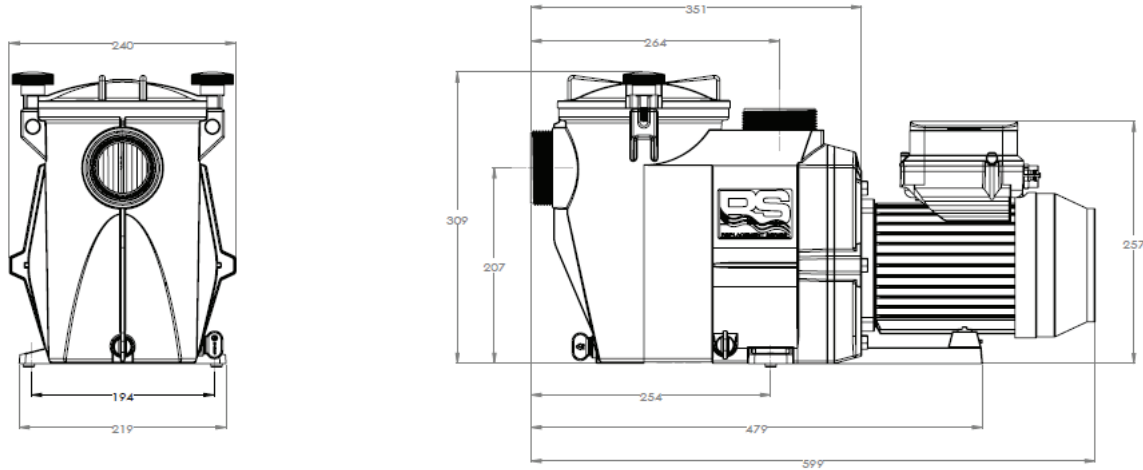

All dimensions in millimeters

INSTALLATION

⚠ WARNING - This product should be installed and serviced only by a qualified professional.

Pump Location

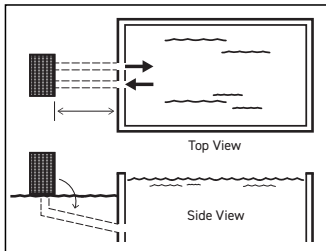

Locate the pump as practically close to the pool as possible. Run the suction line as directly as possible, from pump to pool, in order to reduce friction losses. The suction line should have a continuous slope upward from lowest point in line. Joints must be tight (but not over-tightened). The suction line must not be less than 40 mm in diameter and must be equal to or larger in diameter than the discharge line diameter. Though the pump is designed for outdoor use, it is advised to place pump and filter in the shade to shield them from continuous direct heat. Select a well-drained area that will not flood when it rains. Do NOT install pump and filter in a damp or non-ventilated location. Keep motor clean. Pump motors require free circulation of air for cooling. The maximum Suction Lift without a check valve installed in the suction piping

where the pump can still self prime is 1.8 metres.

Pump Mounting

Install pump on a level concrete slab or other rigid base to meet all local and national codes. Secure pump to base with screws or bolts to further reduce vibration and stress on pipe joints. The base must be level, rigid, and vibration free.

Pump mount must:

- » Allow pump inlet height to be as close to water level as possible.
- » Allow use of a short, direct suction pipe (to reduce friction losses).
- » Allow for valves in suction and discharge piping.
- » Be protected from excess moisture and flooding.
- » Allow adequate access for servicing the pump and piping.

***NOTE: It is recommended that a minimum length of straight piping (shown as "L" in diagram to the right), equivalent to 5 pipe size diameters, be used between the pump suction inlet and any plumbing fittings (elbows, valves, ect).**

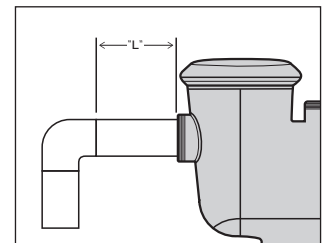

INSTALLATION CONTINUED

Plumbing

Only use Teflon tape or an elastomeric thread sealant suitable for plastic, to seal threaded connections on moulded plastic components. All plastic fittings must be new or thoroughly cleaned before use.

Do Not use Plumbers Pipe Dope or Plumbers Putty as it may cause cracking of the plastic components. The pump suction and outlet ports have moulded in-thread stops. **Do NOT attempt to force threaded connector fitting past this stop.** It is only necessary to tighten fittings enough to prevent leakage. Tighten fitting by hand and then use a tool to engage the fitting an additional 1½ turns. **Do NOT over-tighten fitting** or you may cause damage. If a leak occurs, remove the fitting and remove all traces of the sealing compound from thread. Re-apply fresh sealing compound and re-install the threaded fitting.

Note: If the pump is being installed using the standard Hayward Universal Union that is supplied with the pump then there is no need to apply any type of thread sealant. The union gasket supplied will seal sufficiently.

Fittings (elbows, tees, valves, ect.) restrict flow. For better efficiency use the fewest possible fittings. Avoid fittings that could cause an air trap.

⚠ WARNING - If circulation equipment must remain in the plumbing system during water pressure test, do not apply more than 68 kPa (10 psi) pressure to the system. Be sure water pressure has been released, using the Filter Manual Air Relief Valve, before removing the pump strainer cover.

ELECTRICAL

⚠ WARNING - Risk of Electric Shock.

All electrical wiring must be performed by a qualified electrical contractor, and must conform to Local/State/Federal electrical regulations and the Latest Edition AS/NZ 3000 Wiring Rules. All electrical circuits must be supplied through a Residual Current Device - RCD (Safety Switch), with a residual operating current of 30 mA. Hazardous voltage can shock, burn and cause death or serious property damage. To reduce the risk of electric shock, do NOT use an extension cord to connect unit to the electricity supply.

⚠ CAUTION - Lightning Surge Protector Recommended.

Due to the VSP containing electronic components like a personal computer, Hayward recommends that a surge protector device (SPD) is installed on the feed circuit to the pump by a qualified electrical contractor in accordance with AS/NZS 3000 Australian Wiring Rules.

Bonding

All conductive parts within and around the pool shall be connected together by equipotential bonding conductors and connected to the protective earthing conductor of the electrical equipment as stated in AS/NZS 3000 Wiring Rules Latest Edition. The Super II Economy VS pump is constructed with a double insulated water circuit for extra safety when used on non equipotential bonded pools and spas. This pump can be mounted in swimming pool Zone 1, Zone 2, or outside of the swimming pool zones as per the conditions of AS/NZS 3000 Wiring Rules latest edition.

Nb. If the pump is being mounted in Zone 1 or Zone 2, the motor must be equipotentially bonded.

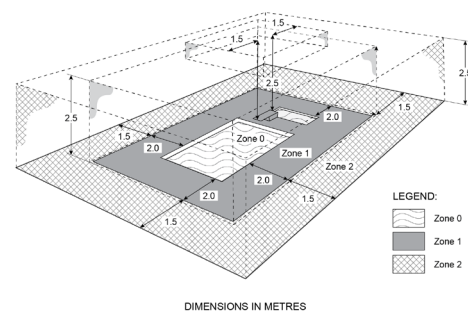

FIGURE 6.12 ZONE DIMENSIONS OF IN-GROUND SWIMMING POOLS

Electrical Specifications

The Variable Speed Drive is fully electronic. Consisting of an integrated power module (IPM) and controller, hard and software with a digital signal processor (DSP). The mains inputs are supplied with a power factor correction (PFC) and EMC filters. The Variable Speed Drive controls a totally enclosed, fan cooled, Permanent Magnet Motor.

START-UP

Prior to Start-Up

If it is necessary to perform a water pressure test prior to the initial use to ensure the plumbing system is functioning properly, then the following criteria should be maintained for this test:

- » Have a professional perform this test.
 - » Ensure all Hayward pump and system components are removed from the system prior to performing the test.
- However:

⚠ WARNING - If circulation equipment must remain in the plumbing system during water pressure test, do not apply more than 68 kPa (10 psi) pressure to the system. Be sure water pressure has been released, using the Filter Manual Air Relief Valve, before removing the pump strainer cover.

⚠ WARNING - All suction and discharge valves MUST BE OPEN, as well as the Filter Air Relief Valve (if available) on filter, when starting the circulating pump system. Failure to do so could result in severe personal injury.

Priming The Pump

Make sure to release all the pressure from the pump and the piping system by using the Filter Manual Air Relief Valve (if available). Close the valves in the suction and discharge lines and remove the strainer cover. Fill the strainer housing with water to suction pipe level. If water leakage occurs from anywhere on the pump or filter, DO NOT start the pump. If no leakage occurs re-install the strainer cover and ensure the Suction, Discharge, and Filter Air Relief Valves are open. Stand at least 2.5 metres from the pump and/or filter and proceed with starting the pump.

⚠ CAUTION - Never Operate The Pump Without Water.

Water acts as a coolant and lubricant for the mechanical shaft seal. Never run the pump dry. Running the pump dry may damage seals, causing leakage, flooding, and voids warranty. Do NOT add chemicals to pool/spa system directly to the pump housing or directly in front of the pump suction. Adding undiluted chemicals directly to the skimmer or strainer basket, may damage the pump and voids warranty.

Starting The Pump

To start the pump, make sure all the suction and discharge valves are open, and the Manual Air Relief Valve on the filter is fully open (if filter has one). Turn the power on at the power point and the pump will start-up and begin priming. Stand back while the pump primes. Due to system variances like Suction Lift, and the length of the suction line, five minutes is not an unreasonable length of time for priming. Only close the Filter Manual Air Relief Valve once a steady stream of water (not air or air mixed with water) is discharging from the valve. If the pump will not start or prime please refer to the troubleshooting section on page eleven (11).

MAINTENANCE

The pump is an electrical device and as such should not be disassembled or serviced by anyone other than a Hayward authorised Service Technician or a qualified electrician. An experienced Pool Service Technician should attend to any other problems that cannot be corrected by routine maintenance. Below are a few maintenance notes and precautionary steps the Pool Owner and Pool Service Technician can take to ensure a safe, efficient and prolonged service by the pump.

- » Clean strainer basket regularly. Do NOT strike the basket to clean it.
- » Super II Economy VS pumps have self-lubricating motor bearings and shaft seals. No further lubrication is necessary.
- » Keep the motor clean. Ensure the air vents and fan are free from obstruction to avoid damage. Do NOT use water to hose off the motor.
- » Occasionally, shaft seals must be replaced due to wear or damage. Replace with a genuine Hayward seal assembly kit only.
- » Do NOT use petroleum based lubricants on gaskets, o-rings, or plastic components. **Use silicone based lubricants only.**
- » Inspect strainer cover o-ring regularly and replace as necessary. Keep strainer cover o-ring lubricated.
- » Tighten the strainer cover and the union nuts by hand only (no wrenches).
- » Never allow the pump to operate without water.

SUPER II ECONOMY INTERFACE

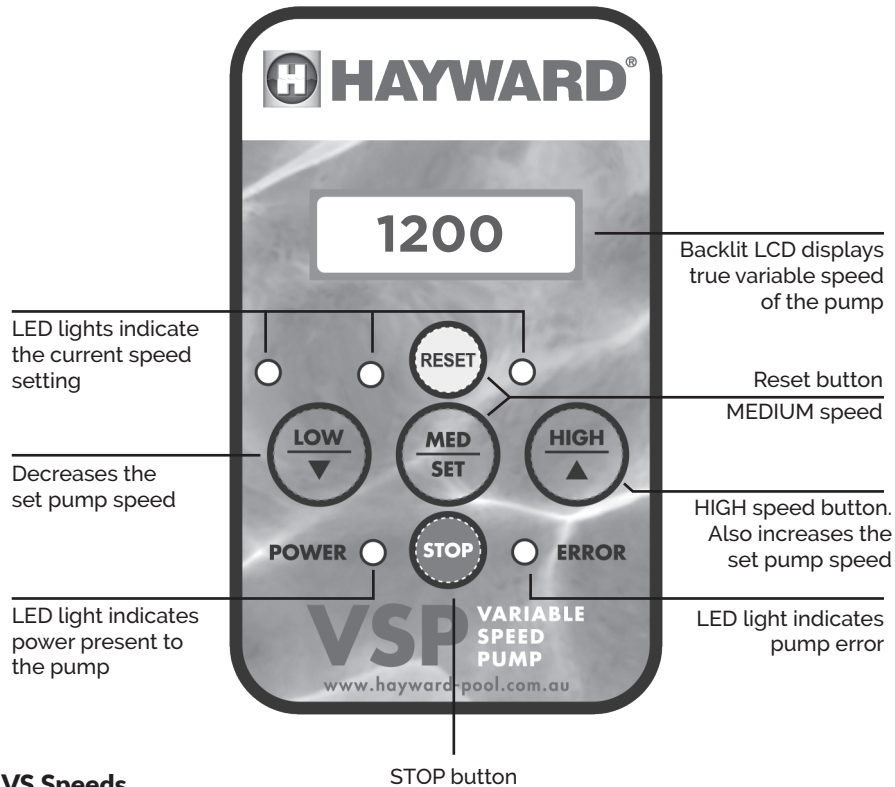

Super II Economy VS Speeds

The Super II Economy VS has three (3) adjustable speeds (LOW, MID HIGH).

Low speed (LOW) is set to a speed of 1500 RPM.

Medium speed (MED) is set to a speed of 2400 RPM.

High speed (HIGH) is set to a speed of 2850 RPM.

The default speeds of the Super II Economy VS can be adjusted to accommodate an individual's swimming pool requirements. This is achieved by:

1. Holding down the desired speed button (LOW, MED, or HIGH) for five (5) seconds until the speed displayed on the LCD screen begins flashing.
 2. Once flashing, the speed can be adjusted lower by pressing the LOW button or it can be adjusted higher by pressing the HIGH button. The speed will change in increments of 20 RPM.
 3. Once the LCD screen displays the desired speed, the speed can be saved by pressing the MED button.
- To reset the speeds back to the factory defaults, hold down the LOW, MED, and HIGH button all at once.

AquaRite+ AU Control

The Super II Economy VS has the ability to have its speeds controlled by the AquaRite+ AU using a 1B-COMCABFAS cable.

Configuration

1. Turn on power to the Super II Economy VS pump. If the pump begins to run, Press the STOP button.
2. Enter the MAIN MENU by holding down the STOP button and pressing the MED button.
3. Press the LOW or HIGH button to scroll through the MAIN MENU until IO appears.
4. Once IO appears on the MAIN MENU, press the MED button to select IO.
5. Press the LOW or HIGH button to scroll through the IO selection until NON appears.
6. When NON appears on the LCD display, press the MED button to select NON.
7. Press the STOP button to exit the MAIN MENU.
8. At the AquaRite+ AU, enter "System Settings". Once in System Settings, scroll down and enter the "Service Menu".
9. Advance through the "Service Menu". When you get to "Filter Pumps", select the VSP as described in the AquaRite+ AU Owner's Manual. The default pump type is "standard" (single speed) and will need to be changed to "Hayward variable".
10. Select "Filtration" under the main menu of the AquaRite+ AU and set a time schedule and speeds for the VSP.
11. Return to the main menu on the AquaRite+ AU.



SERVICING

Important Safety Instructions

Please Read and Follow All Instructions Carefully

Shaft Seal Change Instructions

When servicing electrical equipment, basic safety precautions should always be observed including the following. Failure to follow the instructions may result in injury.

- » Disconnect the pump motor power cord from the power outlet before beginning the shaft seal replacement.
- » Only qualified personnel should attempt to replace the shaft seal. Contact your local authorised Hayward Dealer or service center if you have any questions.
- » Exercise extreme care in handling both the rotating and stationary sections of the two-part replacement seal. Foreign matter or improper handling will easily scratch the graphite and ceramic sealing surfaces.
- » See the "Parts Diagram" on page ten (10) for the pump component locations.

Removing The Motor Assembly

1. Remove the six (6) 3/8" x 2" hex head bolts (Item #27), which hold the motor assembly to the pump/strainer housing (Item #6), using a 9/16" AF spanner or socket.
2. Slide the motor assembly out of the pump/strainer housing (Item #6), exposing the diffuser (Item #18). Pull the diffuser (Item #18) off the seal plate (Item #23) to expose the impeller (Item #20). (The diffuser may remain in the pump/strainer housing. To remove, pull it straight out of the pump/strainer housing.)

Removing The Impeller

1. Insert a flat blade screwdriver through the centre hole and hold it.
2. Remove the impeller (Item #20) by rotating it counterclockwise. The spring portion of the seal assembly is now exposed. Note carefully the position of the spring seal, remove it. Also remove the impeller ring (Item #19) from the impeller and note the way it was installed.

Removing the Ceramic Seat

1. Remove the seal plate (Item #23) from the motor mounting plate (Item #25).
2. Press the ceramic seat with rubber cup out of the seal plate (Item #23). If tight, use a small screwdriver to tap the seal out from the back side of the seal plate.
3. Remove the slinger from the motor shaft (Item #22).

⚠ IMPORTANT - Clean all recesses and parts to be reassembled. Inspect gaskets and replace if necessary.

Seal, Impeller, and Diffuser Installation

1. Clean and lightly lubricate the seal recess in the seal plate (Item #23) with a dilute solution of non-granulated liquid type soap. Gently wipe the polished face of the ceramic seal with a soft, lint free cotton cloth. Lubricate the rubber cup on the ceramic seat and press it firmly into the recess of the seal plate (Item #23), with the polished ceramic surface facing towards you.
2. Slide new plastic slinger (Item #22) onto the start of the motor shaft with tapered end pointing away from the motor. The impeller (Item #20) will slide the slinger into the correct position once it is tightened.
3. Place the seal plate (Item #23) onto the motor mounting plate (Item #25), align the tabs on the seal plate with the grooves on the motor mounting plate. Both parts should have the same outside profile.
4. Gently wipe the black, polished surface of the carbon spring seal assembly (Item #21) with a soft, lint free cotton cloth.
5. Clean and lubricate the impeller hub (Item #20) and press the carbon spring seal assembly (Item #21) onto the impeller hub, with the black polished surface facing away from the impeller.
6. Screw the impeller (Item #18) onto the motor shaft in a clockwise direction and tighten snugly by holding the motor shaft with a flat blade screwdriver as explained earlier. Place the impeller ring (Item #19) back onto the impeller (Item #20) with its flange facing towards the diffuser (Item #18).
7. Place the diffuser (Item #18) over the impeller (Item #20) and onto the seal plate (Item #23), aligning the arrow to the top of the pump. Tap it with the heel of your hand to make it lock into position on the seal plate. Ensure the diffuser O-ring (Item #17) is fitted to the outside of the diffuser (Item #18) inlet.
8. Replace the motor assembly into the pump/strainer housing in the reverse order of the removal steps. Ensure the housing gasket (Item #16) is lubricated and tighten the housing bolts (Item #27) in a cross pattern and evenly.

COMPONENTS & PARTS

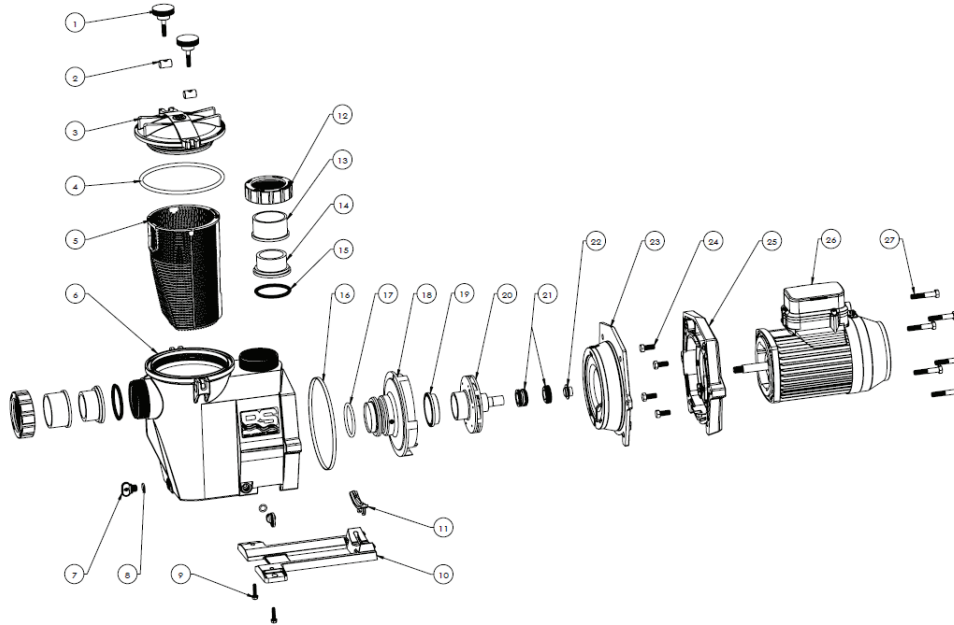

Ref. No.	Part Number	Description	Qty.
1	SPX1600P	HAND KNOB	2
2	SPX1600N	COVER SWIVEL NUT	2
3	SPX3000D	STRAINER COVER	1
4	SPX3000S	STRAINER COVER O-RING	1
5	SPX3000MDI	BASKET	1
6	RS750A2EDI	PUMP HOUSING	1
7	SPX4000P	DRAIN PLUG	2
8	SPX1441Z1	DRAIN PLUG O-RING	2
9	SPX1600Z5	MOUNTING FOOT CAP SCREW	2
10	SPX3000GDI	MOUNTING LEG	1
11	SPX3000QDI4	SPACER MOTOR SUPPORT	1
12	RS750M	UNION NUT	2
13	RS750KDI	2" SKT CONNECTOR	2
14	RS750J	1-1/2" SKT CONNECTOR	2
15	RS750N	UNION GASKET	2
16	SPX3000T	HOUSING GASKET	1
17	SPX4000Z1DI	DIFFUSER O-RING	1
18	SPX3200B3DI	DIFFUSER	1
19	SPX3021R	IMPELLER RING	1
20	SPX3010CDI	IMPELLER	1
21	SPX1600Z2G	MECHANICAL SEAL ASSEMBLY	1
22	SPX1600Q6DI	SLINGER	1
23	SPX3020EDI	SEAL PLATE	1
24	SPX0125Z4	BOLT-3/8-16 X 7/8, 300 SS, HEX	4
25	SPX3000FDI	MOTOR MOUNTING PLATE	1
26	SPXPLDI100VM	MOTOR MOUNTING PLATE	1
27	SPX1600Z4	BOLT 316 SS 3/8" UNC * 2" LONG	6

TROUBLESHOOTING

Motor Will Not Start

1. Ensure the power cord is plugged in and the power is switched on. If the pump still won't start check the availability of power by plugging in another appliance and seeing if it will start.
2. If the pump is controlled via a Chlorinator or Total System Controller, ensure that the controlling device is actually allowing the pump to start.
3. Check for open switches or relays, tripped circuit breakers or blown fuses.
4. If none of the above work, refer to an Authorised Service Agent or another qualified professional.

Pump Will Not Prime

1. Make sure all the suction and discharge valves are open and unobstructed, that the filter manual air relief valve is open, and that the pool water level is above all suction openings.
2. Fill the pump strainer/housing with water to the level of the pump inlet. Ensure that the cover gasket is clean, seated correctly, and lubricated. Tighten the strainer cover by hand only.
3. Make sure the pump strainer basket is clean.
4. Check for loose unions or damaged union o-rings on the suction side. Replace damaged o-rings and tighten the union nuts by hand only (no wrenches).

Low Flow - Generally

1. Check for a clogged or restricted strainer basket or suction line. If the suction line is blocked, contact a qualified repair professional.
2. The pool piping is under size. Correct the piping size.
3. Check for a plugged or restricted discharge line of the filter, valve partially closed (high gauge reading).
 - › Sand Filters: Backwash as per manufacturer's instructions
 - › D.E. Filters: Backwash as per manufacturer's instructions
 - › Cartridge Filters: Clean or replace the cartridge as per manufacturer's instructions
4. An air leak in the suction side plumbing (bubbles issuing from the return fittings) Re-tighten or re-seal threaded suction fittings with Teflon tape. Inspect other plumbing fittings and replace o-rings and tighten as required.
5. Motor bearings made unserviceable by wear, rust or continual overheating. Refer to authorised service agent.
6. Plugged, restricted or damaged impeller. Replace the impeller, including a new shaft seal assembly and slinger.

Motor Cuts Out

Your Hayward pump motor is equipped with *Automatic Thermal Overload Protection*. The motor will automatically shut-off before heat damage build up can occur due to abnormal operating conditions. The motor will auto-restart when a safe heat level is reached. If the motor fails to restart, switch the power off and contact an authorised Hayward Pump Service Technician.

Noisy Pump

1. Cavitations caused by restricted or undersized suction line, an air leak at any joint, low water level in the pool, and unrestricted discharge return lines:
 - › Correct the suction condition or throttle the return lines, if practical. Holding your hand over the return fittings will sometimes prove this, or by putting in a smaller eyeball fitting.
2. Vibration due to improper mounting, etc.:
 - › Mount the pump on a level surface and secure the pump to the equipment pad.
3. Foreign matter in the pump housing or fan cowling:
 - › Loose stones/debris hitting the impeller or the motor cowling fan could be the cause. Clean the pump housing and the fan cowling.
4. Motor bearings noisy from normal wear, rust, overheating, or water ingress due to a worn or damaged shaft seal:
 - › Contact a qualified repair professional.



WARRANTY

STANDARD CONDITIONS - Australia and New Zealand Hayward Pool Products (Australia) Pty Ltd (ABN 083 413 414) ("Hayward Pool Products (Australia)") distributes Hayward Pool Products in Australia and New Zealand and provides the following warranties:

STATUTORY RIGHTS

1. The benefits to the consumer under this warranty are in addition to other rights and remedies of the consumer under the laws in relation to the goods and services to which the warranty relates; and
2. Our goods come with guarantees that cannot be excluded under the Australian Consumer Law. You may be entitled to a replacement or refund for a major failure and for compensation for any other loss or damage. You are also entitled to have the goods repaired if the goods fail to be of acceptable quality and the failure does not amount to a major failure.

LIMITED WARRANTY

Hayward Pool Products (Australia) warrants that its products are free from defects in materials and manufacture for 12 months from date of supply by Hayward Pool Products (Australia) plus 90 days to allow for installation and supply (unless otherwise specified). Hayward Pool Products (Australia) will at its discretion, except in the circumstances described below, either repair or replace any product proven to be defective during the warranty period for either materials of manufacture or alternatively pay the cost of repair or replacement within 90 days of the receipt of the defective product, barring unforeseen delays. This warranty is for domestic installation only, is personal to the original purchaser and does not pass to any subsequent purchaser(s).

- To the extent permitted by law, Hayward Pool Products (Australia) will not be liable for products which fail or become defective during the warranty period as a result of freezing, accident, negligence, improper installation, water chemistry, misuse, tampering or lack of care.
- To the extent permitted by law, except as set out in this Warranty, Hayward Pool Products (Australia) excludes all statutory or implied conditions and warranties and any other liability it may have to the Customer (including liability for indirect consequential loss) that may arise under statute or at law including without limitation for breach of contract, in tort (including negligence) or under any other cause of action.
- To the extent permitted by law, except as set out in this Warranty, Hayward Pool Products (Australia) limits its liability under any condition or warranty which cannot be legally excluded in relation to the supply of Goods and Services to:
 1. Repairing the Goods;
 2. Replacing the Goods or supplying equivalent Goods or Services again;
 3. Paying the cost of replacing the Goods or of supplying equivalent Goods or Services again; or
 4. Paying the costs of repairing the Goods.

Claims made for warranty, labour or infield support will not be accepted by Hayward Pool Products (Australia) unless evidence is provided that installation has been completed in accordance with standard warranty conditions. Please refer to specific program document for details.

WHAT TO DO IF YOU HAVE A WARRANTY CLAIM

The faulty product is to be returned to the place of purchase, or where installed by an approved agent to an authorised warranty agent. No returns will be received directly from end consumers by Hayward Pool Products (Australia). You are responsible for arranging removal of the defective product and arranging installation of the repaired or replacement product, all transportation (and any applicable insurance costs) of transporting the product to the supplier and transporting the replaced or repaired product from the supplier. All returns are subject to Hayward Pool Products (Australia)'s written approval and must be accompanied by either:

1. A Field Inspection Report authorised by the Local Customer Service Manager or Authorised Agent; or
2. A "Return Goods Authorisation" form obtained from Hayward Pool Products (Australia) prior to shipment.

WARRANTY

UNAUTHORISED RETURNS WILL NOT BE ACCEPTED

- All Hayward Pool Products (Australia) warranty parts taken as an across the counter warranty exchange must be held for inspection authorisation has been given by the Local Branch Customer Service Manager to dispose of them. Hayward Pool Products (Australia) reserves the right to provide replacement or credit for any items authorised under this warranty program.
- All claims must be accompanied by a copy of original purchase receipt, clearly stating date of purchase. All serial numbers must place the product within the warranty period or a proof of purchase is required. No claims in respect of the product can be made after the expiration of the warranty period.

Warranty service requests can be faxed to:
Hayward Pool Products (Australia) Pty Ltd.
Fax: 1300 POOLS2 (1300 766571)
Or submitted to your local Hayward Pool Products (Australia)
Branch Office.

A standard form is available to request warranty service. We will require:

- Installation contact information including address, daytime telephone numbers, home phone number, email etc.
- Complete model and serial number
- Proof of purchase (if the serial number was manufactured > 1 year ago).
- Evidence that purchase and Installation was completed in one transaction, by the one business or organisation.
- Nature of problem including specific faults and error codes

To determine if you are eligible for an extended warranty register
your Hayward pool products online today at:
www.hayward-pool.com.au

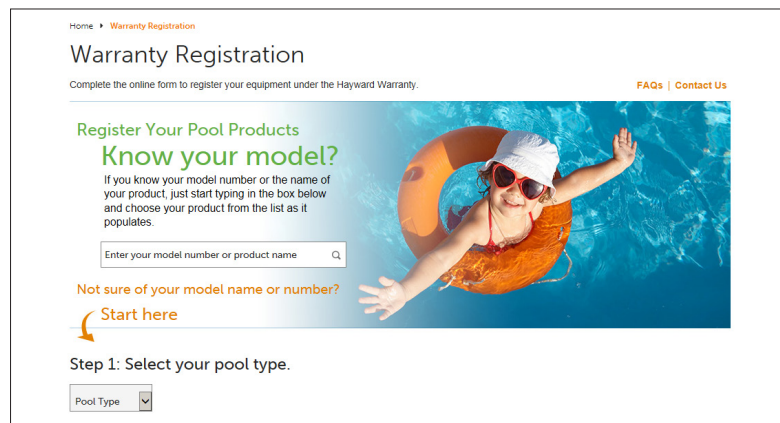

Home » Warranty Registration

Warranty Registration

Complete the online form to register your equipment under the Hayward Warranty. [FAQs](#) | [Contact Us](#)

Register Your Pool Products
Know your model?
If you know your model number or the name of your product, just start typing in the box below and choose your product from the list as it populates.

[Not sure of your model name or number?](#)
[Start here](#)

Step 1: Select your pool type.

Pool Type



NOTES



NOTES





Hayward Pool Products (Australia) Pty Ltd.
 Melbourne-Sydney-Brisbane-Perth
 Email: sales@hayward-pool.com.au | Website: www.hayward-pool.com.au
 PO Box 4384 | Dandenong South VIC 3164
 ABN 66 083 413 414
 Sales Contact Ph: 1300POOLS1 Fax: 1300POOLS2



Hayward and Super II Economy are registered trademarks of Hayward Industries, Inc.
 © 2019 Hayward Industries, Inc.

