

ASTRALPOOL 

BX **POOL & SPA PUMP**

- ✓ High flow, high pressure performance
- ✓ Huge basket reduces maintenance
- ✓ Robust and reliable construction
- ✓ Reduced noise levels



BX POOL & SPA PUMP



The demands on pool equipment in modern pools like large in-ground pools, swim spas, swim jets, larger pool filters, salt-chlorinators and in floor cleaning system place an enormous load on the pump.



STRONG & POWERFUL

The BX Series pump has been designed with great power and control to comfortably meet these demands by delivering a much higher head pressure and a superior overall performance. With reliable external body and high quality components this pump has the highest standards of reliability and durability.



HIGH LEVEL PERFORMANCE

While meeting the demands of your equipment the BX also moves more water, using less power in fewer hours per day. This means lower electricity costs. With a huge hair and lint pot the BX requires less frequent cleaning, making it ideal for holiday home and high leaf areas.



REDUCED NOISE LEVELS

In high density residential area, noise is an issue so the BX pump has been designed to run cooler with less fan noise which means reduced noise level.



WARRANTY

For warranty period, please refer to www.astralpool.com.au/warranty-information.



DIMENSIONS

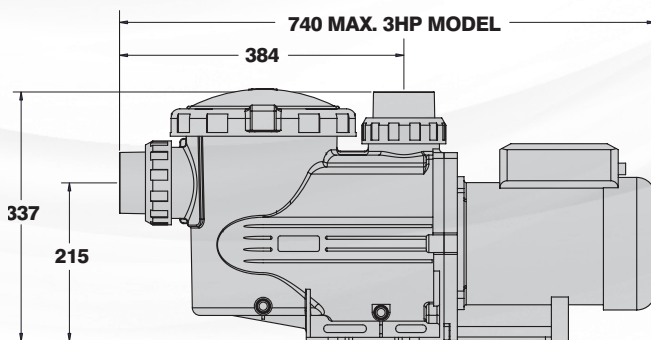

FLOW CHART

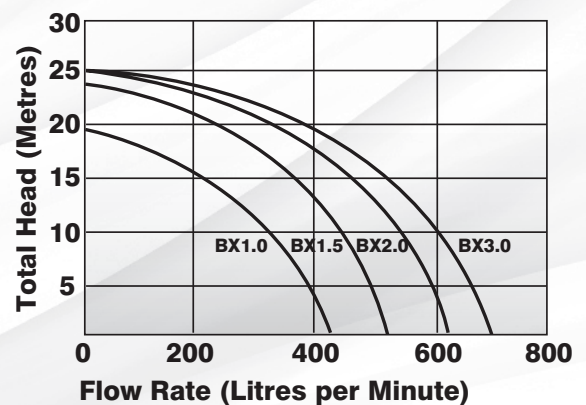

TECHNICAL INFORMATION

Model	Volts	Phase	Input Watts	Horse Power	Flow Rate Max @ 8 m/h	Full Load Amps
BX 1.0	240	Single	1160	1.005	325 lpm	5.0
BX 1.5	240	Single	1645	1.50	440 lpm	7.2
BX 2.0	240	Single	2030	2.00	540 lpm	8.8
BX 3.0	240	Single	2300	3.00	635 lpm	12.5



www.astralpool.com.au
www.astralpool.co.nz

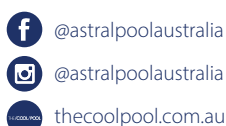

FLUIDRA