

# AQUA BOOSTER AB Series

## SWIMMING POOL & SPA PUMPS



- ~ Flooded suction pump ideally suited for solar, above ground pools and spa installations
- ~ One piece body made from engineering grade, glass reinforced plastic with UV resistance offering extreme durability
- ~ Low noise operation
- ~ Offers high water flow, maximum pressure and energy efficiency
- ~ Durable motor rated for continuous operation
- ~ Available in 6 sizes from 0.50 HP to 2.0 HP
- ~ Limited 3 Year Warranty (Refer to Operating Manual)



## AQUA BOOSTER AB Series SWIMMING POOL & SPA PUMPS

- ~ 100% Owned And Operated Australian Company
- ~ Multiple Applications
- ~ Conveniently Sized
- ~ Durable
- ~ Reliable
- ~ Safe
- ~ Designed To Last
- ~ Powerful
- ~ Low Noise
- ~ Energy Efficient
- ~ User Friendly
- ~ Functional



Available from:

**Disclaimer:** No responsibility will be taken for any errors or omissions in product specifications. The manufacturer reserves the right to alter product specifications without notice.

**Reltech Head Office:**

43-45 Kylta Road  
West Heidelberg  
Victoria 3081  
Australia

Ph: + 613 9459 3838  
Fax: + 613 9459 4038  
Email: office@reltech.com.au

[www.reltech.com.au](http://www.reltech.com.au)

# AQUA BOOSTER AB Series

**Reltech is a 100% owned and operated Australian company.**

Reltech's parent company has over 30 years of extensive experience in the design and manufacture of consumer and industrial related products.

3 years of extensive design, research and development has resulted in what Reltech believes to be one of the most advanced pool and spa pumps ever made and currently available on the market.

The company has invested a significant amount of research and capital towards its goal of creating a new pump which differentiates itself from competing products through a range of features designed to enhance its value and user appeal.

These days consumers are demanding more and do not want to sacrifice quality or performance. They want optimum performance with improved energy efficiency and low noise levels.

Reltech's new range of Australian Made pool & spa pumps is setting a new bench mark in the industry. You can always rely on a Reltech Aqua Booster "AB Series" pump and some of the features & benefits offered are as follows:

## MULTIPLE APPLICATIONS & CONVENIENTLY SIZED

The Aqua Booster "AB Series" flooded suction pump can be used for a variety of applications. Its convenient size, yet powerful motor make it ideally suited for use as a solar pump, above ground pool pump and a circulating heating system pump.

The larger capacity motors (AB 150 & AB 200 Models) also work exceptionally well with swim jet spas and multi jet spas, where high water flow and energy saving is required.

## DURABLE, RELIABLE, SAFE & DESIGNED TO LAST

- Strongly constructed thick walled, one piece pump body made from a high quality engineering grade thermoplastic material that is corrosion resistant. A glass reinforcement and UV additives also ensures the pump is designed to last in all weather conditions.
- Powerful and reliable motor rated for continuous operation ensures a long bearing life. It utilises IP55 construction to protect it from dust and water, making it ideal for moist environments.
- Built in thermal overload protects the motor against damage from overheating.
- A stainless steel pump shaft, a lapped true carbon face and ceramic seal and stainless steel assembly nuts and bolts are just some of the quality components used to ensure ongoing reliability and extended lifecycle.
- Elevated motor stand assembled to main body prevents any warping under high water pressure, ensures balanced support for motor and pump, reduces noise and vibration and keeps moisture away from the motor.
- Meets all stringent Australian Standards approvals (AS 3136:2001) for safety and installation.

## POWERFUL, QUIET AND ENERGY EFFICIENT

- The specially formulated engineering grade material used in conjunction with the design characteristics of the diffuser and balanced impeller system ensures low noise operation whilst offering efficient flooded suction, powerful water flow and filtration with maximum pressure at economical running costs
- All pump performance tests are carried out in accordance with Australian Standard AS 2417-2001 (Roto-Dynamic Pump & Hydraulic Performance Acceptance Test) and NATA requirements (National Australian Testing Authority)

## USER FRIENDLY & FUNCTIONAL

- Self aligning inlet and outlet barrel unions for both suction and discharge ports allowing for quick and easy installation and removal.
- Barrel unions are suitable for both 40mm and 50mm PVC pipe connections.
- Aqua Booster AB Series is covered by a limited 3 year warranty against defects in materials and workmanship (refer to Operating + Installation Manual for full details).

## PUMP PERFORMANCE

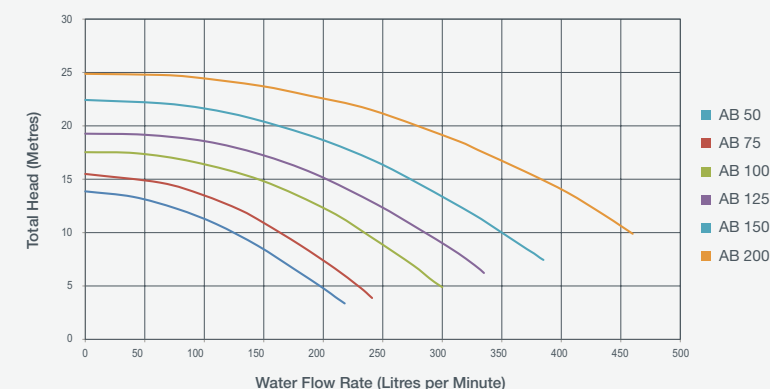

## PUMP DIMENSIONS

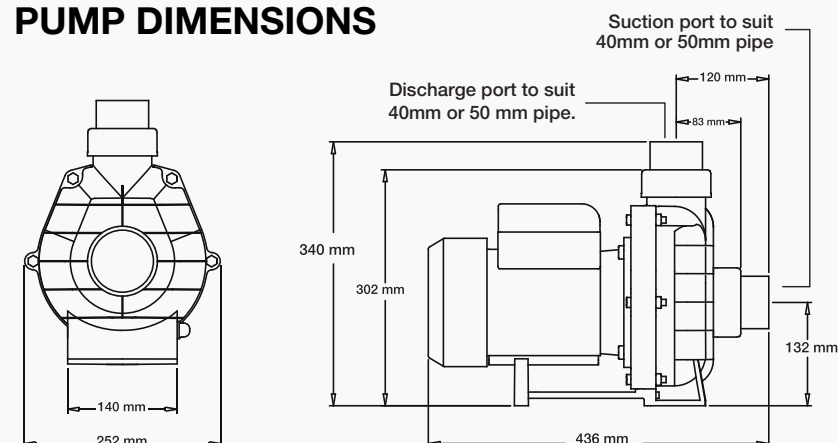

RELTECH PREMIUM AB SERIES MODEL	HP	FLOW RATE @ 8mtr HEAD	VOLTS / PHASE	FULL LOAD AMPS	WATTS INPUT	MAX NOISE dB(A) @ 1mtr
AB 50	0.50	155	240 / 1	2.87	600	55
AB 75	0.75	190	240 / 1	3.29	750	58
AB 100	1.00	260	240 / 1	4.02	910	60
AB 125	1.25	320	240 / 1	4.08	1100	62
AB 150	1.50	380	240 / 1	6.26	1450	63
AB 200	2.00	480	240 / 1	8.53	1950	65

\* All models come fitted with a 3 metre power lead meeting Australian electrical standards.  
 \* Outer carton dimensions: 430L x 270W x 390H (mm)

**AUSTRALIAN MADE**