



Raypak Pool & Spa Gas Heaters

Owner's Guide and Installation Instructions



Residential & Premium Range

	Models	
	Natural Gas	Propane
Residential Pool & Spa Heater Models:	P0131NCO/OD	P0131PCO/OD
	P0200A-N	P0200A-P
	P0280A-N	P0280A-P
	P0350A-N	P0350A-P
	P0430A-N	P0430A-P
Premium Pool & Spa Heater Models:	P0127NNO	P0127PNO
	PC0280A-N	PC0280A-P
	PC0430A-N	PC0430A-P

Please read this manual prior to installing this product. It contains all the necessary technical and installation information that will be required by the contractor to correctly install this system. An electronic copy of these Owner's Guide and Installation Instructions can be downloaded from rheemthermal.com.au. This product must be installed in accordance with the installation instructions and in compliance with standards AS/NZS 5601.1, AS/NZS 3500.4, AS/NZS 3000, the relevant electrical authorities' requirements and all local codes and regulatory requirements.

CONTENTS

RHEEM WARRANTY (Australia Only).....	3
SAFETY AND WARNINGS	5
WHAT TO DO IF YOU SMELL GAS	5
WATER TREATMENT	6
INSTALLATION INSTRUCTIONS	7
PRECAUTIONS	11
PERIODIC MAINTENANCE	12
COMMISSIONING	13
RESET BUTTON	14
OPERATING INSTRUCTIONS.....	16
PROGRAMMING OF POOL OR SPA HEATER CONTROLLER.....	18
ELECTRICAL CONNECTIONS.....	20
DIMENSIONAL & TECHNICAL DATA.....	21
WIRING DIAGRAMS.....	24
POOL HEATER OPERATION FLOW CHART.....	27

Date of installation:	
Model No.	
Serial No.	
Installed by:	
Purchased from:	

This Owners Guide and Installation Instructions manual is provided with the necessary information for the proper installation, operation and maintenance of your Raypak pool or spa heater. Please review and follow these procedures carefully. Keep this manual in a safe and accessible place for easy reference in the future.

⚠ Warning: Upon completion of the installation and commissioning, leave this guide with the householder or responsible officer.

RHEEM WARRANTY (Australia Only)

Raypak Pool & Spa Heater Models: P0127, P0131, P0200A, P0280A, P0350A, P0430A, PC0280A & PC0430A

1. THE RHEEM WARRANTY - GENERAL

- 1.1 This warranty is given by Rheem Australia Pty Limited ABN 21 098 823 511 of 1 Alan Street, Rydalmere New South Wales.
- 1.2 Rheem offer a trained and qualified national service network who will repair or replace components at the address of the water heater subject to the terms of the Rheem warranty. Rheem Service, in addition can provide preventative maintenance and advice on the operation of your water heater. The Rheem Service contact number is 131031 with Contact Centre personnel available 24 hours, 7 days a week to take your call and if necessary arrange a service call for during normal working hours Monday to Friday (hours subject to change).
- 1.3 For details about this warranty, you can contact us on 131 031 or by email at warrantyenquiry@rheem.com.au (not for service bookings).
- 1.4 The terms of this warranty are set out in section 2 and apply to Raypak pool & spa heaters manufactured after 1st October 2015.
- 1.5 If a subsequent version of this warranty is published, the terms of that warranty will apply to pool & spa heaters manufactured after the date specified in the subsequent version.
- 1.6 The application of the Rheem warranty is dependent on payment for the Raypak pool or spa heater being made in accordance with Rheem's Standard Terms and Conditions of Sale.

2. TERMS OF THE RHEEM WARRANTY AND EXCLUSIONS TO IT

- 2.1 The decision of whether to repair or replace a faulty component is at Rheem's sole discretion.
- 2.2 If you require a call out and we find that the fault is not covered by the Rheem warranty, you are responsible for our standard call out charge. If you wish to have the relevant component repaired or replaced by Rheem that service will be at your cost.
- 2.3 Where a failed component is replaced under this warranty, the balance of the original warranty period will remain effective. The replacement does not carry a new Rheem warranty.
- 2.4 Where the pool or spa heater is installed outside the boundaries of a metropolitan area as defined by Rheem or further than 25 km from either a regional Rheem branch office or an Accredited Rheem Service Agent's office, the cost of transport, insurance and travelling between the nearest branch office or Rheem Accredited Service Agent's office and the installed site shall be the owner's responsibility.
- 2.5 Where the pool or spa heater is installed in a position that does not allow safe or ready access, the cost of that access, including the cost of additional materials handling and/or safety equipment, shall be the owner's responsibility. In other words, the cost of dismantling or removing cupboards, doors or walls and the cost of any special equipment to bring the pool or spa heater to floor or ground level or to a serviceable position is not covered by this warranty.
- 2.6 This warranty only applies to the original and genuine Raypak pool & spa heater in its original installed location and any genuine Raypak replacement parts.
- 2.7 The Rheem warranty does not cover faults that are a result of:
 - a) Accidental damage to the pool or spa heater or any component (for example: (i) Acts of God such as floods, storms, fires, lightning strikes and the like; and (ii) third party acts or omissions).
 - b) Misuse or abnormal use of the pool or spa heater.
 - c) Installation not in accordance with the Owner's Guide and Installation Instructions or with relevant statutory and local requirements in the State or Territory in which the pool or spa heater is installed.
 - d) Connection at any time to a pool or spa that does not comply with the guidelines as outlined in the Owner's Guide and Installation Instructions.
 - e) Repairs, attempts to repair or modifications to the pool or spa heater by a person other than Rheem Service or a Rheem Accredited Service Agent.
 - f) Faulty plumbing or faulty power supply.
 - g) Failure to maintain the pool or spa heater in accordance with the Owner's Guide and Installation Instructions.
 - h) Transport damage.
 - i) Fair wear and tear from adverse conditions (for example, corrosion).
 - j) Cosmetic defects
- 2.8 Subject to any statutory provisions to the contrary, this warranty excludes any and all claims for damage to furniture, carpet, walls, foundations or any other consequential loss either directly or indirectly due to leakage from the pool or spa heater, or due to leakage from fittings and/ or pipe work of metal, plastic or other materials caused by water temperature, workmanship or other modes of failure
- 2.9 If the pool or spa heater is not sized in accordance with the guidelines in Raypak's pool & spa heater literature, any resultant fault will not be covered by Rheem's warranty.
- 2.10 The Rheem warranty is not applicable if the installation of the pool or spa heater is carried out by an installer not approved by Rheem or a person who is considered qualified and qualified to do so in the opinion of Rheem.

3. WHAT IS COVERED BY THE RHEEM WARRANTY FOR THE POOL & SPA HEATERS DETAILED IN THIS DOCUMENT

3.1 Rheem will repair or replace a faulty component of your pool or spa heater if it fails to operate in accordance with its specifications as follows:

Models	What components are covered	The period in which the fault must appear in order to be covered	What coverage you receive
Residential P0131, P0200A, P0280A, P0350A & P0430A	All components	Years 1 to 3	Repair and/or replacement of the faulty component, free of charge, when installed at a <u>Single Family Dwelling</u> for the purpose of heating a pool or spa
Premium (Light Commercial) P0127, PC0280A & PC0430A	All components	Years 1 to 3	Repair and/or replacement of the faulty component, free of charge
All above models	Labour	Year 1	Repair and/or replacement of the faulty component, free of charge
Residential P0131, P0200A, P0280A, P0350A & P0430A	All components	Months 1 to 6	Repair and/or replacement of the faulty component, free of charge, when installed at other than a <u>Single Family Dwelling</u> for the purpose of heating a pool or spa
	Labour	Months 1 to 6	Repair and/or replacement of the faulty component, free of charge

4. ENTITLEMENT TO MAKE A CLAIM UNDER THIS WARRANTY

- 4.1 To be entitled to make a claim under this warranty you need to:
- Be the owner of the pool or spa heater or have consent of the owner to act on their behalf
 - Contact Rheem Service without undue delay after detection of the defect and in any event, within the applicable warranty period.
- 4.2 You are **not** entitled to make a claim under this warranty if your pool or spa heater:
- Does not have its original serial numbers or rating labels.
 - Is not installed in Australia.

5. HOW TO MAKE A CLAIM UNDER THIS WARRANTY

- 5.1 If you wish to make a claim under this warranty, you need to:
- Contact Rheem on **131 031** and provide owner's details, address of the pool or spa heater, a contact number and date of installation of the pool or spa heater or if that's unavailable, the date of manufacture and serial number (from the rating label on the heater)
 - Rheem will arrange for the pool or spa heater to be tested and assessed on-site.
 - If Rheem determines that you have a valid warranty claim, Rheem will repair or replace faulty parts and components and or the pool or spa heater in accordance with this warranty.
- 5.2 Any expenses incurred in the making of a claim under this warranty will be borne by you.

6. THE AUSTRALIAN CONSUMER LAW

- 6.1 Our goods come with guarantees that cannot be excluded under the *Australian Consumer Law*. You are entitled to a replacement or refund for a major failure and for compensation for any other reasonably foreseeable loss or damage. You are also entitled to have the goods repaired or replaced if the goods fail to be of acceptable quality and the failure does not amount to a major failure.
- 6.2 The Rheem warranty (set out above) is in addition to any rights and remedies that you may have under the *Australian Consumer Law*.

SAFETY AND WARNINGS

For your safety do not operate this appliance before reading this instruction booklet!

Improper installation, adjustment, alteration, service or maintenance can cause injury or property damage. For assistance or additional information consult your Raypak distributor, qualified installer, or Rheem® Service agent.

For your own safety only have this appliance installed by a qualified gas fitter who must issue you with a compliance certificate when complete. Persons taking medications which induce drowsiness should not use spas. Persons with a medical history of heart disease circulatory or blood pressure problems, or diabetes should obtain their Doctor's advice prior to using a spa.

SAFETY AND WARNINGS

- This pool heater is only intended to be operated by persons who have the experience or the knowledge and the capabilities to do so.
- This pool heater is not intended to be operated by persons (including children) with reduced physical, sensory or mental capabilities, or lack of experience and knowledge. Children should be supervised to ensure they do not interfere with the pool heater.
- The pool heater uses 240 Volt AC electrical power for operation of the control systems. The removal of the access cover(s) will expose 240 V wiring. They must only be removed by an authorised or qualified person.
- DO NOT modify this pool heater.
- DO NOT use or store **flammable materials** in or near this pool heater. Flammable liquids (such as petrol), combustible materials (such as newspapers) and similar articles must be kept well away from the pool heater and the draught diverter or flue terminal.
- DO NOT spray **aerosols in the vicinity** of the pool heater whilst it is operating. Gases from some aerosol sprays become corrosive when drawn into a flame.
- DO NOT store **swimming pool chemicals, household cleaners, etc.**, near the pool heater.
- DO NOT place articles on or against this pool heater or in contact with the flue terminal. Ensure the flue terminal is not obstructed in any way at any time.
- DO NOT use Propane / Butane gas mixtures in a Propane model. A Propane model is designed to operate on Propane only. The use of Propane / Butane mixture, such as automotive LPG fuel, in a Propane model is unsafe and can cause damage to the pool heater.
- DO NOT operate with panels, covers or guards removed from the pool heater.
- DO NOT enclose this pool heater (applies to external installations only).
- DO NOT operate this appliance whilst a suction plate is fitted in the skimmer box for cleaning your pool. E.g.: With a vacuum hose suction operated cleaning device
- DO NOT use this appliance to heat water for drinking.
- DO NOT enter water heated by this appliance without testing temperature first. Prolonged exposure to elevated water temperatures may be hazardous to your health.

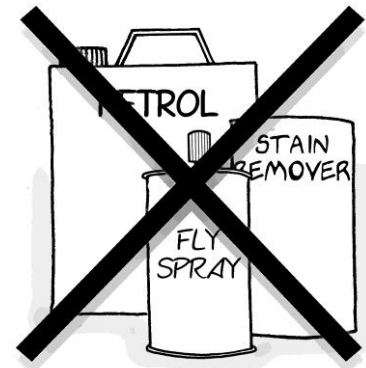

WHAT TO DO IF YOU SMELL GAS

- DO NOT try to light this appliance.
- DO NOT touch any electrical switch.
- TURN OFF the gas supply at the meter immediately, contact a qualified gas fitter or Rheem Service.

NOTE: Some gases are heavier than air and it may be necessary to check for gas leaks at floor level.

Ceramic Fire tile refractory is used in this appliance. For a current Material Safety Data Sheet (MSDS) go to www.morganthermalceramics.com/en-gb/datasheets/safety-datasheets and enter "MSDS 244" in the search. Ceramic Fire tile refractory may produce smoke when the appliance is first started. Ensure area is well ventilated when lighting appliance. Avoid breathing fumes.

WATER TREATMENT

IMPORTANT! CORROSIVE WATER VOIDS YOUR WARRANTY

This pool or spa heater must be installed in accordance with this advice to be covered by Rheem's warranty. This pool or spa heater is manufactured to suit the water balance specified on the table below. However, there are some known water chemistries which can have detrimental effects on the pool or spa heater and its operation and/or life expectancy. This pool or spa heater must be installed in accordance with this advice to be covered by the Rheem warranty

For your health and the protection of your heater it is essential that your water quality is always chemically balanced. Only incorrect water balance will cause your heat exchanger to corrode. After corrosion occurs, subsequent water chemical tests may not reveal the water quality at the time that the damage occurred. Do not replace any corroded parts before bringing your water quality back into balance. The following table provides a guide to good water balance:

	Fibreglass Pools (less than 31C)	Fibreglass Spas (more than 31C)	Other Pools & Spas
pH	7.3 - 7.4	7.3 - 7.4	7.6 - 7.8
Total Alkalinity (PPM)	120 - 150	120 - 150	80 - 120
Calcium Hardness (PPM)	200 - 300	200 - 300	200 - 400
Salt (PPM)	6,000 MAX	6,000 MAX	6,000 MAX
Free Chlorine (PPM)*	2 - 3	2 - 3	2 - 3
Langelier Saturation Index	±0.3	±0.3	±0.3

*** FREE CHLORINE MUST NOT EXCEED 4 PPM**

*** FREE BROMINE MUST NOT EXCEED 5 PPM**

There are several factors that need to be considered in order to avoid damage to your heater.

- Automatic chemical dosing devices and chlorinators are usually more efficient in heated water and/or covered pools/spas. Unless controlled, they may lead to excessive chlorine levels which can damage your heater.
- If the sanitising level in your pool/spa is too high, your test kit or that of your pool shop may not show the correct chlorine/bromine concentration.
- If your salt chlorinator operates for extended periods whilst the pool is being heated and the weather is overcast or your pool is enclosed / covered, the chlorine may exceed the recommended levels.
- The balance of your pool water depends on a combination of pH, total alkalinity, calcium hardness and temperature. Combined, these factors enable the Langelier Saturation Index to be calculated. It is essential these factors are maintained at the recommended levels so that the water is balanced and the sanitation of your pool will be optimal.
- When adding acid to lower your pH, it must **always** be added in small quantities and spread uniformly over the entire pool surface. **DO NOT** add acid one litre at a time. Instead, add a cupful each day. **DO NOT** add acid into the skimmer box. This may potentially lead to corrosion of your heat exchanger. Refer to "Periodic Maintenance" on page 12.

INSTALLATION INSTRUCTIONS

⚠ Warning: This appliance must be installed in accordance with all local state and federal laws including the regulations of any government bodies and in complete accordance with these instructions. Where these instructions are contrary to the law or regulations of an appropriate government body those laws or regulations should take precedence subject to there being no compromise to safety.

BEFORE YOU COMMENCE INSTALLATION

1. Read these instructions in full.
2. Check that the pool or spa heater you have been supplied is suitable for the gas type that is available.
3. Ensure that your gas fitter checks that the gas supply pressure is between the minimum and maximum specified on the heater data plate.
4. Confirm that the heater you have purchased is suitable for the location it is to be installed, i.e. Outdoor or Indoor.
5. Check that your pool system pump will provide water flow between the specified minimum and maximum flow rates required for the heater to operate.
6. Remove packaging and timber base before installation.
7. Complete all details on the page 2 of this book.

PRODUCT APPLICATIONS

Raypak "Residential" pool & spa heaters are designed and built for installation in applications where the intention of its use is to heat a pool or spa of a single family dwelling. Its use in an application other than this may shorten its life. Residential heaters are not intended for installation in commercial applications such as multi residential apartments. For these applications a Raypak "Commercial" pool or spa heater (also referred to as "Premium") pool or spa heater should be selected.

See **WARRANTY & SERVICE** sections in this book for details of the different Rheem warranties dependent on the heater type and its intended application.

HEATER LOCATION

The heater must be located so that any possible water leaks will not damage adjacent areas or structures. When such locations cannot be avoided it is recommended that a suitable safe tray be constructed and installed by your plumber. This must not restrict air required for combustion.

The heater must be located on a level non-combustible surface such as concrete. All packaging must be removed before installation.

OUTDOOR HEATERS

Raypak pool & spa heaters are built for outdoor installations as standard. The installation must conform to **AS/NZS 5601.1** as a minimum. They must not be installed in any enclosed structure or under eaves, roof overhangs, or pool decks. Outdoor pool & spa heaters must be installed at least **1500mm** from any window or room ventilation opening. They must also have no obstructions above the appliance.

If installing the heater on a raised base, the base must be non-combustible and contain no air openings or perforations. Drafts from below the heater can affect its operation.

High Wind Areas

Raypak pool & spa heaters are atmospherically vented and so may not function correctly in areas of sudden changing air pressure often caused by high or variable wind speeds. In some instances, it may be necessary to install either a **Raypak High Wind Top** or a **Raypak Induced Draft Fan** to ensure correct operation. These options should be discussed with Rheem before installation.

In areas of "constant extreme winds" or in areas where high winds frequently occur, it is necessary to locate the heater a minimum of one (1) metre from high vertical walls, or install a wind break so that the heater is not positioned and exposed in the direction of the prevailing winds.

INDOOR HEATERS

Combustion / Ventilation Air

Indoor pool & spa heaters must only be installed in a protective enclosure or properly constructed room, with ventilation in accordance with **AS/NZS 5601.1**. Ventilation must be provided via two permanent openings, one at ceiling level and one at floor level. Minimum vent area must be in accordance with **AS/NZS 5601.1**. Minimum opening dimensions in the vent must be at least **6mm**.

For indoor applications the pool or spa heater must have at least the minimum clearances specified in the table below on page 8. Increased clearances should be provided where possible to improve serviceability. If the pool or spa heater is not installed in accordance with the sufficient and safe space for ease of service around the unit, Rheem advises that the pool or spa heater will be disconnected and removed to enable servicing.

Note: The following table details minimum acceptable clearances (mm) for serviceability and for **indoor installations** on non-combustible floors **only**:

Models P0127, P0200, P0280, P0350, P0430, PC0280, PC0430

Rear	Front	Water Side	Non-Water Side	Above
Non-Combustible Surfaces				
150	750	600	150	1200
Combustible Surfaces				
500	750	600	500	1200

Models P0131*

Rear	Front	Left	Right	Above
Non-Combustible Surfaces				
300	750	300	300	1200
Combustible Surfaces				
500	750	500	500	1200

***Model 131 suitable for outdoor installations only.**

Note: For outdoor installation clearances please refer to AS/NZS5601.1:2013

Air supply to the room must not be affected by mechanical exhausts of other equipment such as bathroom or kitchen fans, spa blowers or air-conditioning equipment, etc.

FLUEING

Flueing must be in accordance with **AS/NZS 5601.1**. Only the correctly-sized Raypak draft diverter must be fixed to the heater and connected to a properly constructed flue, vented to atmosphere using approved fittings and cowl. Alteration to the Raypak draft hood or reduction in cross section of connected flueing will **void the Rheem warranty**.

Where standard flueing options cannot be implemented Rheem should be contacted for flueing advice.

Additional ductwork connected to the Raypak draft hood must be self-supporting and allow the removal of the Raypak pool or spa heater and draft hood without removal of the flue. The flue system beyond the Raypak draft hood must in no circumstances be supported by the heater.

Where practical, the flue should be run vertically. Lateral flueing is allowed but must rise a minimum of 20mm per 1m of lateral run and the total lateral run must not exceed 50% of the total flue height.

⚠ WARNING! Do not use an unlined masonry chimney as the flue for this appliance.

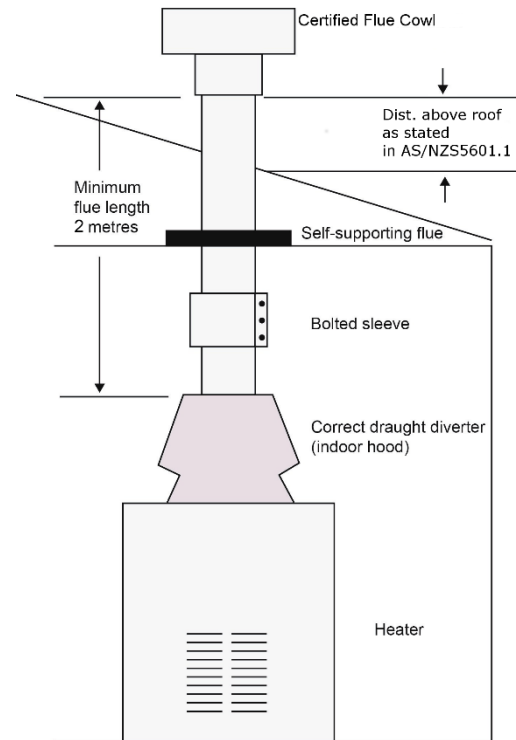

Indoor Hood Conversion

To convert Model P0200 to P0430 and PC0280 to PC0430 heaters from outdoor configuration to indoor:

1. Remove all screws from the appliance top panel and discard sheet metal.
2. Fit the indoor flue “stack adaptor” supplied with the indoor conversion kit to the flue collector and screw in position.
3. Fit the “draft diverter” over the indoor flue “stack adaptor” spigot.
4. Ensure that all connections are secure and will not allow products of combustion to escape into the room.

To convert Model P0127 heaters from outdoor configuration to indoor:

1. Remove all 4 screws on the supports for the appliance’s top hood and discard hood.
2. Fit the indoor “draft diverter” to the flue collector and screw in position.
3. Ensure that all connections are secure and will not allow products of combustion to escape into the room.

GAS SUPPLY

The gas supply pipe and gas meter must be sized so that both are capable of providing sufficient gas for all gas appliances on the site to operate at the same time. Insufficient gas supply will cause the heater to operate below its designed performance or not at all.

Correct pipe sizing for the gas fitting line should be obtained from **AS/NZS 5601.1**. During commissioning of the heater the burner pressure must be adjusted by the gas fitter to conform to the specifications provided on the Raypak pool or spa heater rating label - located on the left hand side of the heater (refer to “). The heater and its gas line must be fully leak-tested prior to normal operation.

Note: It is more important than ever that when installing a new gas pool or spa heater, the commissioning must be carried out by a qualified **plumber**. Gas supply companies are increasingly supplying natural gas to new installations with 2.75kPa. This means if the gas pressure is not adjusted to the correct working pressure (see rating label) the heater will be over gassed and cause serious damage within minutes. This damage is not covered under the Rheem Warranty.

 **Warning:** Excessive Gas Pressure will damage the gas valve and **void the Rheem warranty**.

HOW LONG WILL THE POOL & SPA HEATER LAST

Your pool & spa heater is supported by a manufacturer's warranty (refer page 3). There are a number of factors that will affect the length of service the pool or spa heater will provide. These include but are not limited to the water chemistry, the water flow rate, service & maintenance program and usage pattern. Refer to Precautions on page 11 and Periodic Maintenance on page 12.

Flue clearances

This information sheet has been prepared to assist gasfitters in providing the correct flue clearances for gas appliances. The location of the flue terminal of a balanced flue appliance, room-sealed appliance, a fan-assisted appliance or an appliance designed for outdoor installation shall comply with the figure below.

For further information contact the Gas Safety Technical Information Line on 1800 652 563.

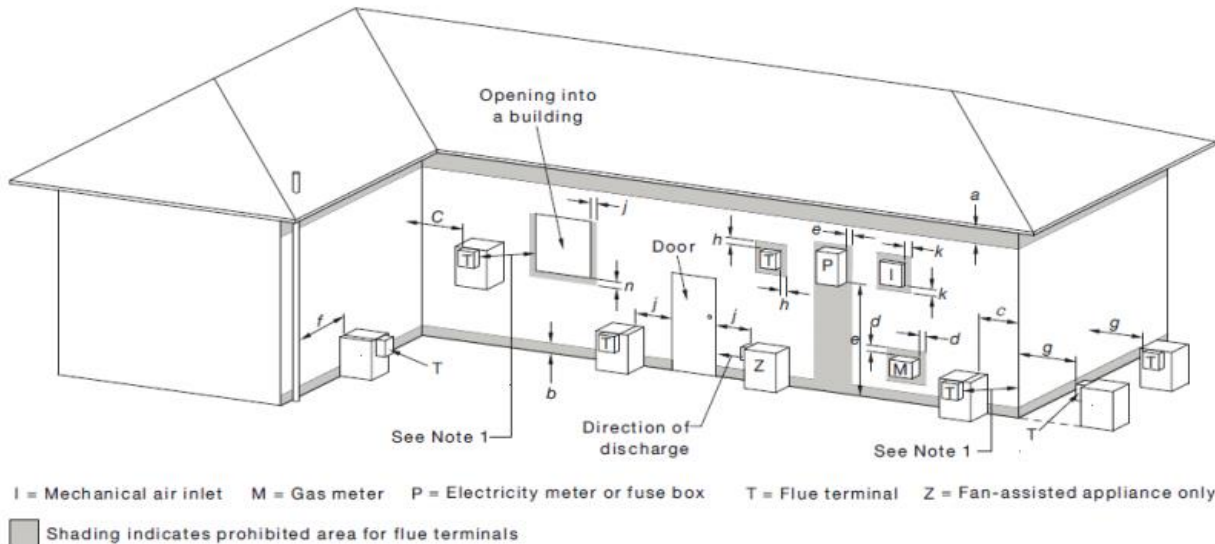

Ref.	Item	Minimum clearances mm	
		Natural draft	Fan assisted
a	Below eaves, balconies and other projections:		
	Appliances up to 50 MJ/h input	300	200
	Appliances over 50 MJ/h input	500	300
b	From the ground, above a balcony or other surface *	300	300
c	From a return wall or external corner *	500	300
d	From a gas meter (M) (see Note 5) (see Clause 5.11.5.9 for vent terminal location of regulator)	1 000	1 000
e	From an electricity meter or fuse box (P) [†] (see Note 5)	500	500
f	From a drain pipe or soil pipe	150	75
g	Horizontally from any building structure * or obstruction facing a terminal	500	500
h	From any other flue terminal, cowl, or combustion air intake *	500	300
j	Horizontally from an openable window, door, non-mechanical air inlet, or any other opening into a building with the exception of sub-floor ventilation:		
	Appliances up to 150 MJ/h input*	500	300
	Appliances over 150 MJ/h input up to 200 MJ/h input*	1 500	300
	Appliances over 200 MJ/h input up to 250 MJ/h input*	1 500	500
	Appliances over 250 MJ/h input*	1 500	1 500
	All fan-assisted flue appliances, in the direction of discharge	—	1 500
k	From a mechanical air inlet, including a spa blower	1 500	1 000
n	Vertically below an openable window, non-mechanical air inlet, or any other opening into a building with the exception of sub-floor ventilation:		
	Space heaters up to 50 MJ/h input	150	150
	Other appliances up to 50 MJ/h input	500	500
	Appliances over 50 MJ/h input and up to 150 MJ/h input	1 000	1 000
	Appliances over 150 MJ/h input	1 500	1 500

* Unless appliance is certified for closer installation.

[†] Prohibited area below electricity meter or fuse box extends to ground level.

PRECAUTIONS

Warning: Ceramic fire tile refractories are used in Raypak pool and spa heaters. Refractories must be treated with care because they can be harmful by inhalation and irritating to the skin, eyes and respiratory system.

DURING FIRST FIRING OF THE WATER HEATER

- Fumes and smoke may be produced.
- Avoid breathing fumes and ventilate the area to clear.
- Production of smoke should cease within 30 minutes.

WHEN HANDLING

- Minimise airborne dust.
- Wear an approved mask or respirator.
- Avoid any contact with the skin and eyes.
- Wear suitable loose-fitting, long-sleeved clothing or disposable overalls.
- Wear gloves and eye protection.
- Consult Occupational Health and Safety Authorities for any further information.

AFTER HANDLING

- Rinse any exposed skin areas with clean water.
- Wash work clothing separately.

REMOVAL OF USED PRODUCT

- Follow the precautions as detailed in the section 'WHEN HANDLING' above, over-exposure to dust formed after service may cause respiratory disease as cristobalite, a form of crystalline silica, may be formed above 900 degrees Celsius.
- Seal used product in a disposable bag and dispose of via normal garbage collection methods.

Consult Occupational Health and Safety Authorities for further Information regarding removal of used ceramic fibre lining.

- Where damage to property can occur in the event of the pool or spa heater leaking, the pool or spa heater must be installed in a drained safe tray. Construction, installation and draining of a safe tray must comply with AS/NZS 3500.4 and local codes and regulatory authority requirements
- The pool or spa heater must be maintained in accordance with the Owner's Guide and Installation Instructions. Refer to Periodic Maintenance on page 12.
- If the pool or spa heater is to be used in a commercial application you should ensure that you have adequate redundancy within the pool or spa heating system design. This should ensure the continuity of heating the pool or spa in the event that the pool or spa heater was to become inoperable for any reason. We recommend you seek advice from your Rheem representative, your plumber or specifier about your needs and building redundancy into your pool or spa heating system.
- The most frequent cause of damage to a Raypak pool or spa heater is incorrect water balance resulting from overdosing of chemicals. All chlorinators must feed downstream of the pool or spa heater and have an anti-siphoning device to prevent chemical back up into the heater when the pool or spa heater pump is shut off

PERIODIC MAINTENANCE

Recommended Weekly Maintenance (Residential & Premium models)

Minor maintenance should be performed every week by the dwelling occupant. The minor maintenance includes:

- Monitoring your chlorine and pH levels on a weekly basis or everyday if the pool or spa is in high use.
- Total Alkalinity and Calcium hardness levels can be monitored less frequently
- Regularly check that the heater cabinet and air louvres are free of any dust, lint and debris
- Do not operate the pool or spa heater if water balance is outside the parameters as specified on page 6 under water treatment as this will void the Rheem warranty.

Annual Service (Residential & Premium models)

It is a requirement of Rheem and all gas authorities that the pool or spa heater be serviced at least once per year. Where it is used in a specific application, e.g. pool heating, it would be practical to perform the service at the commencement of the pool heating season, or at any time there is an indication of a problem.

To ensure you receive timely and accurate service assistance state the model number, serial number and type of gas used. This information will be found on the heater data plate.

Your local Rheem Service centre will arrange for your service or recommend a qualified service agent or organisation. Annual maintenance should only be performed by a qualified service technician. The maintenance includes:

- Inspection/Cleaning of pilot assembly, including injector
- Inspection/Cleaning of main burner injectors and burner bars
- Inspection/Cleaning of the heat exchanger
- Inspection of file tiles for damage or deterioration and replacement where necessary
- Leak testing heat exchanger and waterways
- Operation of Pressure Relief Valve (if fitted) manually to ensure the drain is clear and the valve reseals
- Leak testing gas connections
- Inspection/Cleaning of air vents and louvers
- Testing of all safety devices
- Testing of controls

Biannual Service (Premium models only).

Biannual/Six monthly maintenance should only be performed by a qualified service technician. The maintenance includes:

- Inspection/Cleaning of pilot assembly, including injector
- Inspection/Cleaning of main burner injectors and burner bars
- Inspection/Cleaning of the heat exchanger
- Inspection of file tiles for damage or deterioration and replacement where necessary
- Pressure testing heat exchanger and waterways
- Operation of Pressure Relief Valve (if fitted) manually to ensure the drain is clear and the valve reseals
- Leak testing gas connections
- Inspection/Cleaning of air vents and louvers
- Testing of all safety devices
- Testing of controls

 **Warning:** Always isolate all electrical connections to the heater, including any pump connections, before commencing any service work. Only a qualified service technician should carry out work on your pool or spa heater. Regular service (at least annually) should be carried out to ensure that the gas valves and burners are clean and free from obstruction or damage and that the heat exchanger has not been impaired by sooting or corrosion.

It is recommended that prior to commencing operation of your pool or spa heater each year a service inspection be undertaken by a qualified service technician. Please call Rheem Service on **131 031**.

COMMISSIONING

COMMISSIONING MUST ONLY BE UNDERTAKEN BY A QUALIFIED PERSON WHO IS FAMILIAR WITH SAFE COMMISSIONING PROCEDURES.

⚠ Warning: Ceramic fire tile refractories are used in Raypak pool and spa heaters. Refractories must be treated with care because they can be harmful by inhalation and irritating to the skin, eyes and respiratory system.

Refer to "Precautions" on page 11 for the precautions to be taken when the water heater is first installed and operated.

PRE-START CHECKS

- Ensure all packaging materials have been removed from the pool/spa heater.
- Conduct a visual inspection of the pool/spa heater and equipment for any damage or installation problems and report as necessary.
- Ensure that the pool/spa heater is clean and the surrounding area is clear of all combustible and flammable materials.
- For an indoor installation, check that combustion air openings are not obstructed.
- Test ALL gas connections for leaks, using soapy water. **NOT A NAKED FLAME**
- Check that the correct power supply is available and the circulation pump is supplied from the same electrical circuit as the pool/spa heater.
- Check that the ventilation to the unit complies with the requirements of **AS/NZS 5601.1** and local authority regulations.
- If mechanical ventilation or power fluing is provided, check the operation of the fan(s) and interlocks.
- Check that the flue complies with the appropriate regulations and is fitted with an approved cowl.
- Ensure that the main gas isolation valve is closed.

OPERATIONAL CHECKS *(must be completed by installer prior to leaving the site)*

- Turn on the pool/spa heater, then confirm start-up of the electronic controller and "O" indication in display.
- Turn on pump and confirm that "O" disappears from display.
- Test the operation of the pool/spa heater with no gas flow to confirm its operation up to lockout stage, then turn off the power.
- Open the gas isolation valve and switch on power to the pool/spa heater.
- With the main burner lit, check the inlet gas pressure with a manometer. (refer to "[Gas Inlet Pressure](#)" on page 17).
- Check the pool/spa heater gas train and components for gas leaks using soapy water. **NOT A NAKED FLAME**
- Set the burner gas pressure to that shown on the rating label (refer to "[Gas Pressure Adjustment](#)" on page 17).
- Make a visual check of the burners. The flame should be blue with a well-defined pattern. A yellow or floating flame indicates restricted air openings or incorrect burner pressure setting.
- Check that the flue on an indoor installation is drawing correctly.

⚠ Warning: It is normal for the pool/spa heater to produce some smoke and possibly condensation for the first thirty (30) minutes of operation from new (refer to "PRECAUTIONS" on page 11).

Upon completion of the installation and commissioning of the pool/spa heater, leave this guide with the householder or responsible officer. **DO NOT** leave this guide inside of the cover of the pool/spa heater, as it may interfere with the safe operation of the pool/spa heater or ignite when the pool/spa heater is turned on.

Explain to the householder or responsible officer the functions and operation of the pool/spa heater.

RESET BUTTON

Your Raypak pool or spa heater incorporates a red reset button located on either the front control panel or right hand side panel, together with a power failure recovery circuit.

When power is first supplied to the pool or spa heater, or restored after being interrupted or isolated, the red reset button will illuminate briefly before the power failure recovery circuit operates. To operate the heater when power is first supplied or restored after being interrupted or isolated:

1. The red reset light should automatically go out and the control panel should display "OFF". If the light does not go out, the heater must be serviced by a qualified service technician.
2. Press and release the POWER button on the control panel. The control panel will display the current water temperature.
3. If power is being supplied for the first time the internal time clock will need to be set. This may also apply if power has been interrupted or isolated for some time and then restored. To reset the heater's internal time clock follow the procedure 'Setting Time & Day' located on page 18 of the Owners Guide and Installation Instructions.
4. If power is being supplied for the first time any required auto mode time periods will need to be programmed. If power has been interrupted or isolated and then restored, any auto mode time periods previously programmed may need to be reprogrammed.

To program auto mode time periods follow the 'Programming Mode' procedure on page 19.

The heater can now be operated as normal.

If during operation the heater stops working and the red reset button illuminates, check the following:

1. Ensure skimmer box is not jammed and that the filter is not blocked and is clear of any foreign matter. I.e. leaves & debris.
2. Ensure all valves are in the correct position and that there is adequate water flow through the heater.

If these conditions are checked and found to be satisfactory and the red reset button cannot be reset and/or continues to be illuminated; the heater must be attended by a qualified service technician. **For service contact Rheem Service on 131 031**

WATER – PRESSURE, CONNECTIONS, & FLOW

Pressure Relief Valve

If the filtration system incorporates any valves or accessories that may isolate the heater from the pool or spa, a pressure relief valve must be fitted to the heater. Specifications and installation advice relating to this valve can be obtained from Rheem.

Flow Switch

Note: If the installation is outside of our suggested limits (as per the below diagram) a flow switch kit (Part/No: **96009224**) will need to be fitted to the heater. Specifications and installation advice relating to the Flow Switch can be obtained from Rheem.

MAXIMUM HEIGHT ABOVE OR BELOW WATER LEVEL

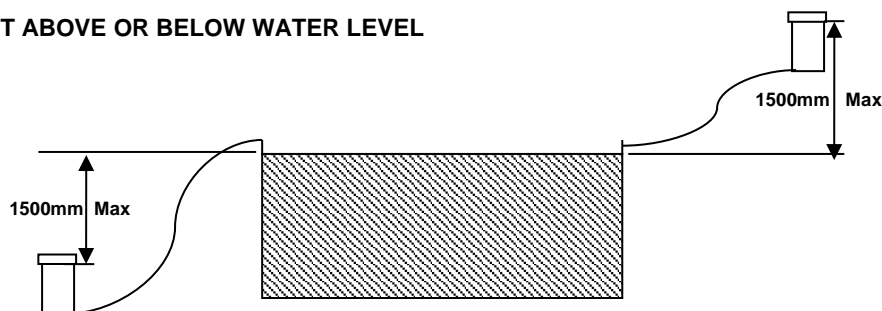

Pressure Switch Function

The pool or spa heater is supplied standard with a Pressure Switch that when correctly adjusted will only allow the heater to operate when there is sufficient water pressure. **In every installation the Pressure Switch operation must be checked** as part of the commissioning process.

Warning: The Pressure Switch is only suitable as a means of ensuring adequate water pressure if the Inlet/Outlet piping of the heater is less than 1500 mm above or below the water level of the pool. For installations which exceed this range a **flow switch** must be installed. Specifications and installation advice relating to this switch can be obtained from Rheem.

Pressure Switch Adjustment

For Models: P0131, P0200 to P0430

1. Remove the In/Out access cover (water connection side) to gain access to the pressure switch.
2. Steps 2-9 as per below

For Models: P0127, PC0280, PC0430

1. Remove the Return access cover (opposite to water connection side) to gain access to the pressure switch
2. Check that all water valves are correctly positioned to enable normal water flow to the pool or spa heater
3. Start the system pump and ensure that water is flowing through the pool or spa heater
4. Turn the power on at the pool or spa heater.
5. Adjust the set point of the pool or spa heater to 40°C.
6. If the heater lights, the water pressure is within the pressure switch range and the pressure switch will not need to be adjusted
7. If the heater did not light after Step 6, turn the Pressure Switch knurled adjustment wheel located on the pressure switch in a **clockwise** direction until the heater ignites, then continue a further ¼ of a turn
8. To test the adjustment made turn off the pump to the pool or spa heater and the main burner should immediately go out. If the heater does not go out, the heater must be turned off immediately and Rheem service should be contacted on 131 031
9. The pump should be cycled on and off several times to ensure that the adjustment is correct

Chemical Dosing

The pool or spa heater must be installed in accordance with this advice to be covered by the Rheem warranty. All Raypak pool and spa heaters must be installed after the pool/spa system pump and prior to any chemical dosing or chlorination system. Chemical dosing or chlorination systems must be located as far from the heater as possible and a backflow prevention device must be installed between the heater and such systems.

Ideally any chemical dosing system should also be installed below the water connection level of the heater.

Installation above this level may lead to chemical seepage back into the heater even with a backflow prevention device. This will result in damage to the heat exchanger and will **void the Rheem warranty**.

⚠ Warning: *Chemicals that are allowed to enter the heater without having first passed through the pool or spa will damage the heat exchanger of the heater and consequently will **void the Rheem warranty**.*

Never add chemicals to the skimmer box, leaf basket, or near the return line from the pool to the heater.

Water Connections

Raypak pool and spa heaters with either **Polymer** or **Bronze** headers are designed for direct connection to PVC pipe. Use only Class 12 PVC fittings or better.

Water Flow

Correct flow rate of water to the heater is critical for correct operation.

Raypak pool & spa heaters are fitted with an internal by-pass to redirect excessive water flow however should the flow rate exceed that given in the table below; an external PVC type by-pass valve must be fitted. Setting of the valve must be done at the time of commissioning.

⚠ Warning: *Sooting caused by incorrect setting of a by-pass valve or failure to fit a by-pass valve when required will **void the Rheem warranty**.*

The Raypak pool and spa heaters must be commissioned by the installer prior to normal operation or handover. Installation or connection of the heater to the gas supply by an unqualified trades' persons will **void the Rheem warranty**.

The installer must also supply the owner with a compliance certificate at the completion of commissioning.

Min/Max Flow Rates

Model	Min. l/s	Max. l/s
P0131	1.5	6.9
P0127	1.5	3.7
P0200	1.5	6.9
P0280 & PC0280	1.6	6.9
P0350	3.0	6.9
P0430 & PC0430	3.0	6.9

OPERATING INSTRUCTIONS

HEATER CONTROLLER LAYOUT

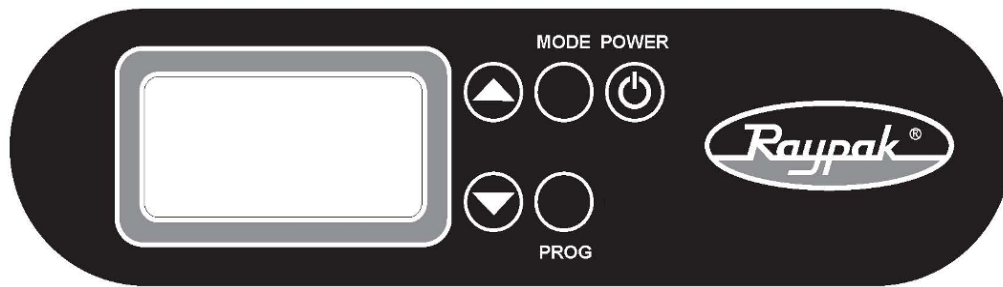

Note: The **MODE** button switches between **Pool** and **Spa** modes.

BEFORE OPERATING

1. Ensure that the immediate area around the heater is clear of all combustible materials including chemicals and gases.
2. Familiarise yourself with the hand operated gas isolation valve located outside your heater.
3. Ensure that the heater is free from obvious damage.
4. Ensure that the correct power connections have been made and are able to be isolated.
5. Reset Button must be pressed prior to initial operation once heater is powered on. (Reset lamp is illuminated)

SERVICE CODES & FAULT FINDING

If the controller detects an error in one of its safety circuits it will display a Service code. The codes are as follows:

1. PO – No mains power to the unit
2. O – Insufficient water pressure
3. F1 – Wiring or Electronics Fault
4. F2 – Main sensor open circuit
5. F3 – Main sensor short circuit
6. F4 – Secondary sensor short circuit

When the mains power supply is interrupted, the unit will revert to a standby mode utilising the back-up capacitor supply. (This will last for at least two hours providing the unit has had sufficient operating time to charge the capacitor).

The unit will not provide heat whilst there is no mains power. The controller will, however, retain its settings as long as the capacitor has charge. Upon resumption of mains power, the unit will revert to the state it was in prior to the mains power being interrupted.

Whenever the controller is on and there is insufficient water pressure to activate the pressure switch it will display the letter "O". There is either insufficient water pressure in the system (e.g. pump is not operating) or the pressure switch requires adjustment.

In the event of an over-temperature situation, the heater will shut down and lockout. The reset lamp will be illuminated and the reset button must be pressed to resume operation. (This is a safety requirement of AS4560). Should an over temperature situation arise regularly, you should check the following:

1. Ensure skimmer box is not jammed and that the filter is not blocked.
2. Ensure all valves are in the correct position and that there is adequate water flow through the heater.

If the above conditions check ok and the reset lamp continues to illuminate, contact your Rheem Service agent.

PO error relates to no power supply reaching the pool or spa heater from the electricity mains supply GPO power point.

F1 error relates to a wiring fault as a result of a wire coming loose or dislodged from the wiring loom or printed circuit board (PCB)

F2, F3 and F4 are errors relating to the unit's temperature sensors. The errors arise from problems with the sensors or the sensor connections.

In the event one of these errors is displayed you should contact Rheem Service on 131 031.

OVER-TEMPERATURE SHUTDOWN

If the inlet water temperature exceeds 45°C, the heater will shut down and require a manual reset to restart. Once the unit has cooled to approx 35°C, the red reset button will illuminate and need to be pressed, after which the reset lamp will go out and the heater will resume normal operation.

Note: There is no immediate indication of the over temperature shutdown; the control panel will still indicate a call for heat (small flame symbol). If the heater has gone out during normal operation, and the flame symbol appears on the display, allow up to 4 hours for the heater to cool (If the pump has ceased operation the reset time may be shortened by restarting the pump). If the reset button has failed to illuminate and the temperature display reads less than 32°C, **contact your Rheem service agent on 131 031.**

OPERATING INSTRUCTIONS

1. Before switching the heater On, ensure all water flow control valves are in their correct position. This can be tested by manually operating the system pump and ensuring that water is flowing through the heater.
2. Ensure that the gas supply is turned on.
3. Press the **POWER** button on the face panel of the heater. The heater will display the current water temperature of the pool.
4. Press the **▲** button on the control panel of the heater until the desired temperature set point is reached.
5. If initial operation, or if reset lamp is on, press the reset button
6. The heater will ignite when the set point temperature is above the measured water temperature.

Note: *The heater will not ignite if there is no water flow through the heater.*

7. If the heater does not ignite after 90 seconds, turn off the power by pressing the **POWER** button and **wait 1 minute** before repeating all steps.
8. If the pool or spa heater does not light on the second attempt, turn off the heater and isolate the gas supply and contact your qualified installer or Rheem.

GAS INLET PRESSURE

IMPORTANT – CHECK the gas supply pressure at the inlet to the water heater with the water heater and all other gas burning appliances in the premises operating (burners alight). The minimum gas supply pressures are:

Natural Gas - **1.13 kPa**

Propane - **2.75 kPa**

If this minimum cannot be achieved, it may indicate the meter or the gas line to the water heater is undersized. It is important to ensure that an adequate gas supply pressure is available to the water heater when other gas burning appliances, on the same gas supply, are operating.

GAS PRESSURE ADJUSTMENT

To adjust the burner pressure on a water heater with the White Rodgers 36H gas control, proceed as follows:

- Remove the gas control cover.
- Remove the screw and washer from the outlet pressure tap.
- Attach a manometer to the outlet pressure tap.
- Remove the cap from the pressure regulator adjuster.
- With the main burner operating, adjust the pressure regulator (clockwise to increase or anti-clockwise to decrease) to achieve the burner pressure as specified on the rating label.
- Turn off the water heater.
- Replace the cap on the pressure regulator adjuster.
- Disconnect the manometer and replace the pressure tap screw and washer.
- Check for gas leaks, using soapy water.
- Replace the gas control cover.



TEMPERATURE SELECTION

 **Warning:** Prolonged exposure to elevated water temperatures can be hazardous.

Temperature selection is made by selecting either the ▲ or ▼ arrow buttons located on the face of the heater controller. After depressing either of these buttons the current desired temperature set point will be displayed. Continuing to press either button will alter the heater set point. Once the desired set point temperature is selected the display will return to show the current water temperature, after a short delay.

For continued manual operation of the heater in this manner ensure that the display is not showing AUTO. If AUTO is displayed pressing the **PROG** button to return the heater to manual operation.

MODE SELECTION (POOL/SPA)

The **MODE** button on the control panel enables both the pool and spa temperatures to be set independently. The two set point temperatures are stored by the heater controller and are used when the desired mode is selected.

To select the desired mode press the **MODE** button. The selected mode is shown on the heater display. The heater will then operate according to the mode selected.

If the Pool mode is selected, the heater will heat the water until the pool set point temperature is reached. If Spa mode is selected the heater will heat the water until the spa set point temperature is reached.

PROGRAMMING OF POOL OR SPA HEATER CONTROLLER

The controller located on the front of your Raypak pool or spa heater is capable of both manual and programmable operation. The following instructions describe how the controller may be programmed for timer operation.

Before the controller can be programmed the time of day clock and day of week must be set.

SETTING TIME & DAY

Before the pool or spa heater is operated the internal pool or spa heater time clock should be set. Each and every time the pool or spa heater has been isolated at the GPO, e.g. for service, this process must be repeated.

1. Connect the pool or spa heater to a 240V 10A Waterproof GPO and turn on.
 2. With the controller displaying **OFF**, simultaneously press and hold the ▼ and **PROG** buttons to access the time set mode.
 3. The system time will then flash on the display. To adjust the time of day, press the ▲ or ▼ buttons until the correct time is reached.
 4. Once the time has been set, press and release the **PROG** button to access the day of week mode.
 5. The day will flash on the display. To adjust the day, press the ▲ or ▼ buttons.
 6. Press and release the **PROG** button to lock the day setting and return the control to the OFF mode.
-

AUTO MODE

Auto mode allows the controller to:

1. Turn the pool heater on or off over 4 separate time periods each day.
2. Control water temperature.
3. Control mode settings (Pool or Spa)

Auto mode can be selected by pressing the **PROG** button and releasing. AUTO should now be displayed. The heater has been factory set with four default time periods. These will be used if no other program is set and AUTO is selected on the controller. The following table shows the factory set AUTO mode program settings. The controller will retain all program settings even with the removal of the power supply.

Timer Period	Start Time	Temp ° C	Mode
1	6:00am	24	Pool
2	10:00am	OFF	Pool
3	2:00pm	24	Pool
4	6:30pm	OFF	Pool

PROGRAMMING MODE

IMPORTANT!

The pool or spa heater must be in **AUTO** mode before timer periods can be set. **AUTO** mode is selected by pressing the **PROG** button.

All time periods must be programmed, even if not required and must be set in the correct time sequence for the controller to operate correctly in AUTO mode. **Note:** *The programming operation can be exited at any time by selecting the **POWER** button.*

Example:

TIMER PERIOD	START TIME	If these time periods are set the operation sequence will be as follows: Period1>Period2> Period4 <u>Period 3 will be ignored</u>
1	7:00am	
2	9:00am	
3	8:30am	
4	9:00pm	

1. With the controller in the AUTO mode, switched "On" and displaying the current water temperature, press the **PROG** button for at least 5 seconds to access the programming mode. The time of day will be displayed, ensure the day and time are correct. To set the time and day, refer section "Setting Time and Day" on page 18.
2. To enter programming mode, press and hold the **PROG** button for at least 5 seconds to access the day selection. The day of week and "SET" will flash. Note: Whilst the **PROG** button is held down, the screen will momentarily return to the temperature display.
3. The first item to be programmed is the day of the week. Use the ▲ or ▼ buttons to scroll through the days of the week. Press **PROG** to lock in the day selection/s.
4. The start time of period 1 will then flash. Press the ▲ or ▼ buttons to adjust the start time. Press the **PROG** button to lock in the start time.
5. Either POOL or SPA will now flash in the display indicating the mode selected. Use the **MODE** button to toggle between Pool and Spa modes. Press the **PROG** button to lock in the selected mode.
6. The desired temperature for the selected mode must now be set for period 1. On first use, the temperature is set to "OFF" by default. Use the ▲ or ▼ buttons to scroll through the temperature settings. The minimum set temperature is 18°C. Pressing the ▼ button when the temperature is at 18°C will select the OFF mode for period 1. Press **PROG** to lock in the temperature selection.
7. The AUX control number will now flash and is only applicable where a Raypak EIB is installed. To skip this step and proceed to timer period 2, press the **PROG** button.
8. The display will now move to timer period 2 which may be programmed in the same manner.

Note: *All four timer periods must be programmed even if all temperature selections outputs are set to off or not required. The program function will operate each timer period in the sequence 1 to 4.*

9. The display will now return to its normal position.

CHILD LOCK FUNCTION

The child lock function will render all 6 controller switches inactive.

1. To activate the child lock function press and hold both the ▲ and ▼ buttons for 10 seconds. The lock symbol will be displayed.
2. To cancel the child lock function press and hold the ▲ and ▼ buttons for 10 seconds.

ELECTRICAL CONNECTIONS

⚠ WARNING! – ALL ELECTRICAL WORKS MUST BE COMPLETED BY AN QUALIFIED ELECTRICIAN

⚠ Warning: Isolate all power sources prior to **commencing any installation, service, or other work.** See also warnings included on the heater.

POWER CONNECTION(S)

The heater includes a loosely coiled 3-pin 240VAC power lead for connection to a mains power 10A Waterproof GPO. This connection is required for operation of the heater.

The heater should be properly connected to a GPO that is suitable for either indoor or outdoor use. Prior to connection inspect the supplied power connection lead for any damage.

DO NOT connect the heater to any power source if there is any sign of damage.

FLUE DILUTION KIT & EXTERNAL THIRD PARTY POOL CONTROLS

Models P0200, P0280, P0350, P0430, PC0280 & PC0430 Only

These models include a second terminal strip, which enables connection of the optional Dilution Fan Kit (for Indoor installations only) and an external thermostat control (see figure below).

The Dilution Fan Kit is installed as shown in the wiring diagram supplied with the kit, between terminals A1 and A2, after removing the corresponding link.

To install an external thermostat control, remove the link between terminal 1 and 2 and connect the thermostat between the terminals (voltage-free, normally-closed contacts only).

External Controls Terminal Strip

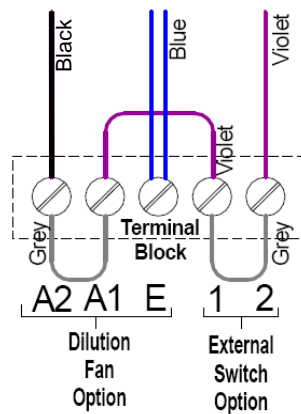

DIMENSIONAL & TECHNICAL DATA

Models P0200A, P0280A, P0350A, P0430A

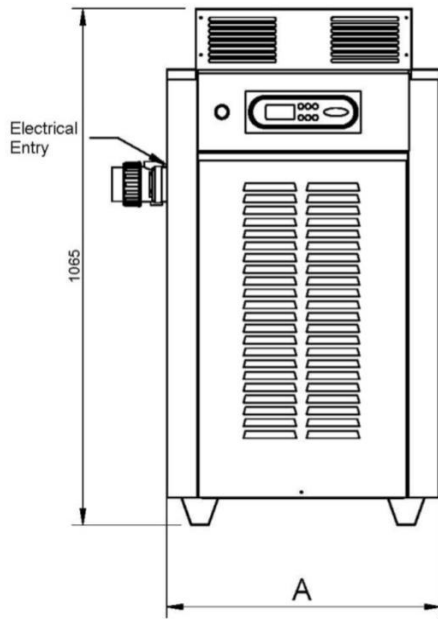

FRONT

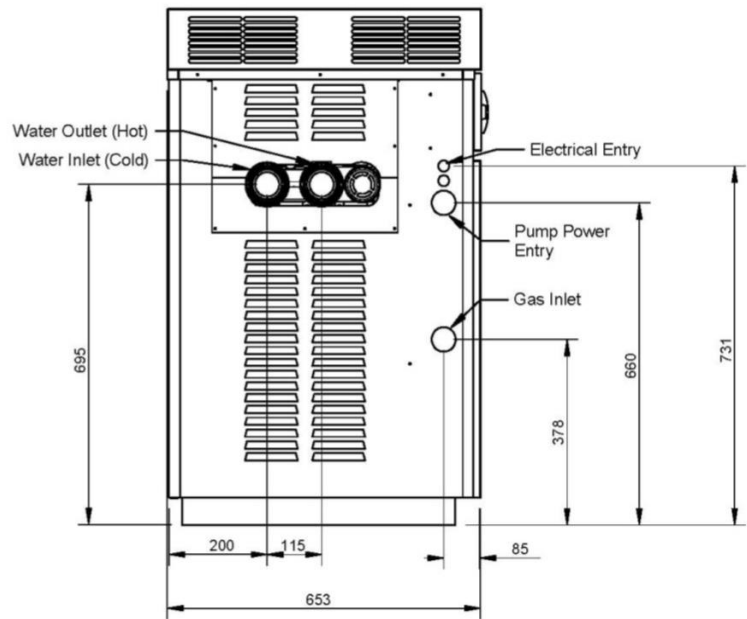

LEFT SIDE

MODEL	GAS	INPUT (MJ/h)	OUTPUT (kW)	OPERATING BURNER PRESSURE (kPa)	INJECTOR DIA. (mm)	PILOT INJECTOR DIA. (mm)	HEIGHT OUTDOOR (mm)	WIDTH (A)* (mm)	DEPTH (mm)	WEIGHT (kg)
P0200A	Natural	196	44	0.77	1.90	0.58	1,055	465	650	70
	Propane	185	41	2.5	1.10	0.35				
P0280A	Natural	278	62	0.77	1.90	0.58	1,055	570	650	75
	Propane	261	58	2.5	1.10	0.35				
P0350A	Natural	343	76	0.77	1.90	0.58	1,055	655	650	85
	Propane	323	72	2.5	1.10	0.35				
P0430A	Natural	420	94	0.77	1.85	0.58	1,055	745	650	90
	Propane	396	88	2.5	1.07	0.35				

Models PC0280A & PC0430A

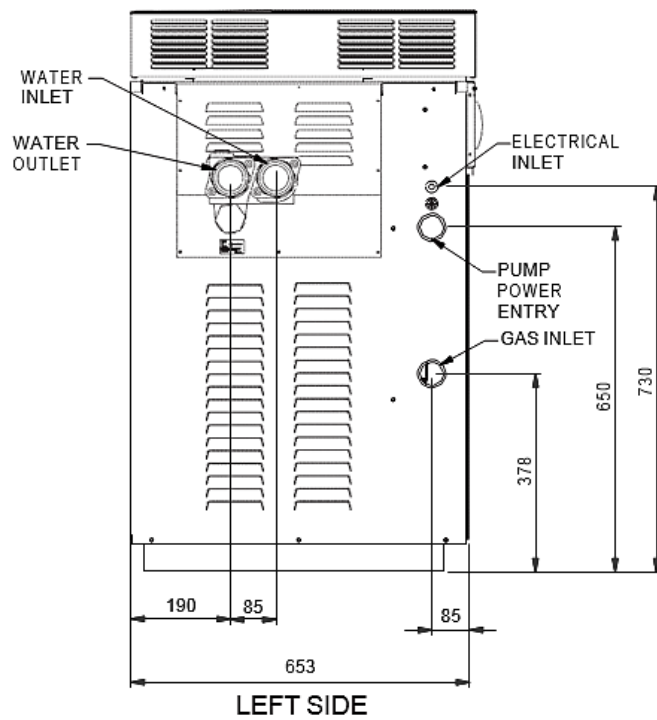
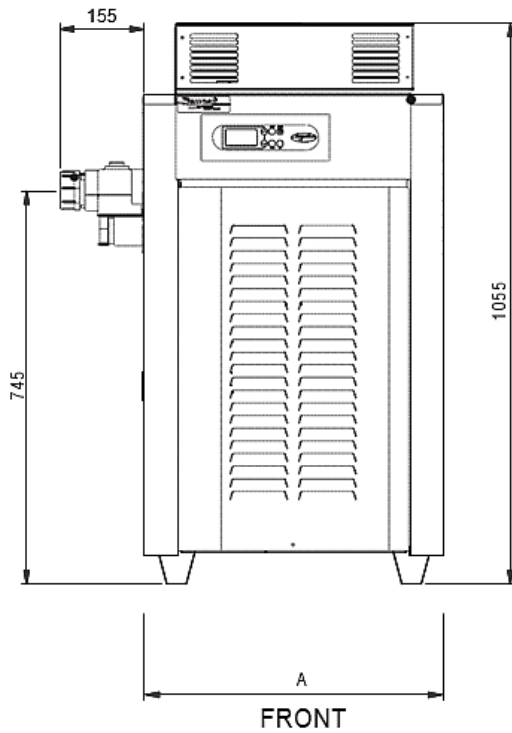

MODEL	GAS	INPUT (MJ/h)	OUTPUT (kW)	OPERATING BURNER PRESSURE (kPa)	INJECTOR DIA. (mm)	PILOT INJECTOR DIA. (mm)	HEIGHT OUTDOOR (mm)	WIDTH (A)* (mm)	DEPTH (mm)	WEIGHT (kg)
PC0280A	Natural	278	62	0.77	1.90	0.58	1,055	570	650	75
	Propane	261	58	2.5	1.10	0.35				
PC0430A	Natural	420	94	0.77	1.85	0.58	1,055	745	650	90
	Propane	396	88	2.5	1.07	0.35				

* Please allow for an additional 150mm for the width of the header inlet and outlet coupling connections

Model P0131

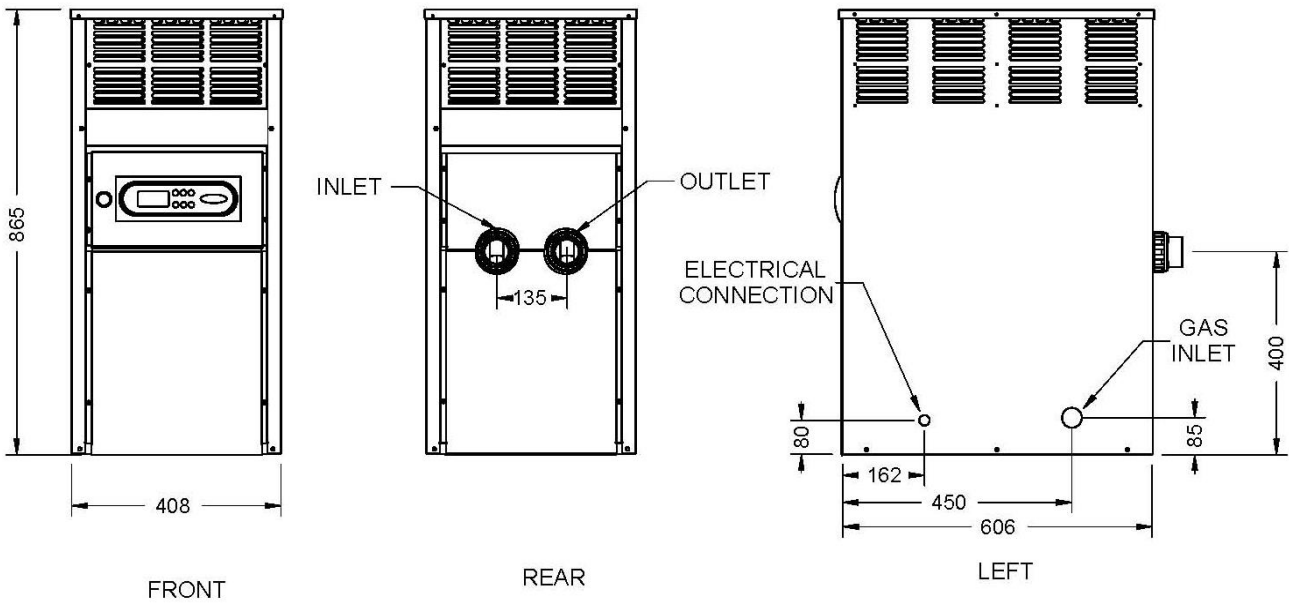

MODEL	GAS	INPUT (MJ/h)	OUTPUT (kW)	OPERATING BURNER PRESSURE (kPa)	INJECTOR DIA. (mm)	PILOT INJECTOR DIA. (mm)	HEIGHT OUTDOOR (mm)	WIDTH (A)* (mm)	DEPTH (mm)	WEIGHT (kg)
Spartan P0131	Natural	120	24	0.85	1.36	NA	865	408	606	35
	Propane	134	27	2.56	0.85	NA				

* Please allow for an additional 80mm for the depth of the capron header inlet and outlet coupling connections

Model P0127

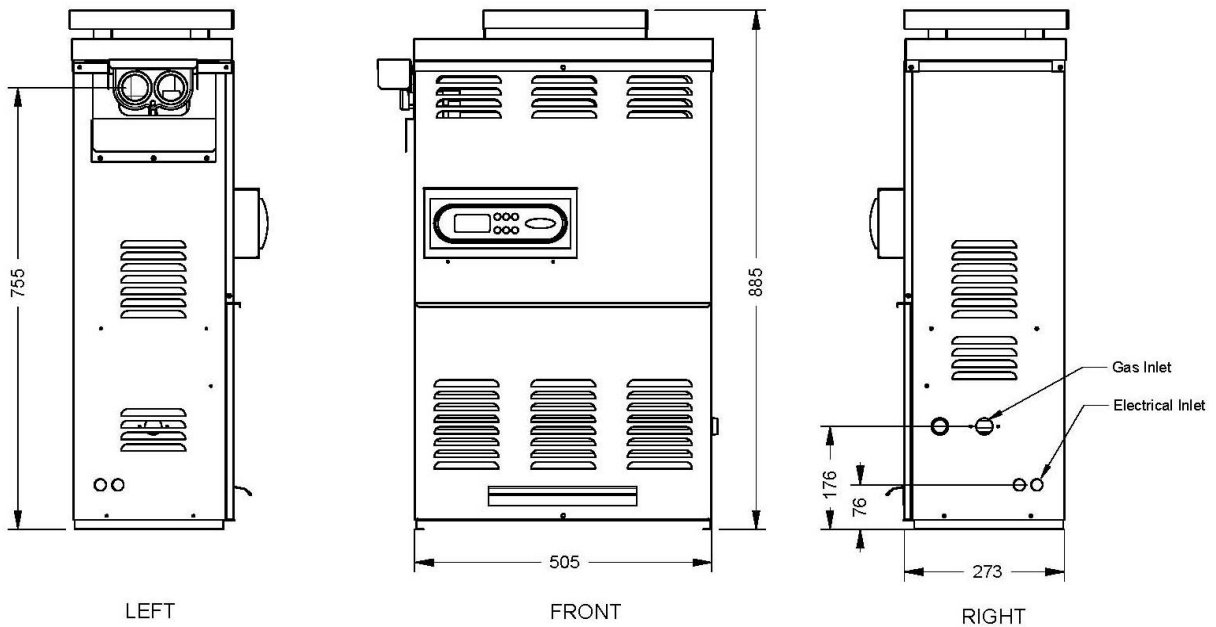

MODEL	GAS	INPUT (MJ/h)	OUTPUT (kW)	OPERATING BURNER PRESSURE (kPa)	INJECTOR DIA. (mm)	PILOT INJECTOR DIA. (mm)	HEIGHT OUTDOOR (mm)	WIDTH (A)* (mm)	DEPTH (mm)	WEIGHT (kg)
P0127	Natural	110	24	0.77	1.90	NA	895	505	280	42
	Propane	103	23	2.56	1.10	NA				

WIRING DIAGRAMS

Models P0200A, P0280A, P0350A, P0430A, PC0280A & PC0430A

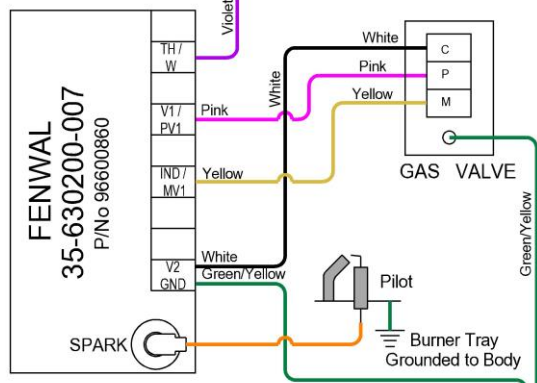
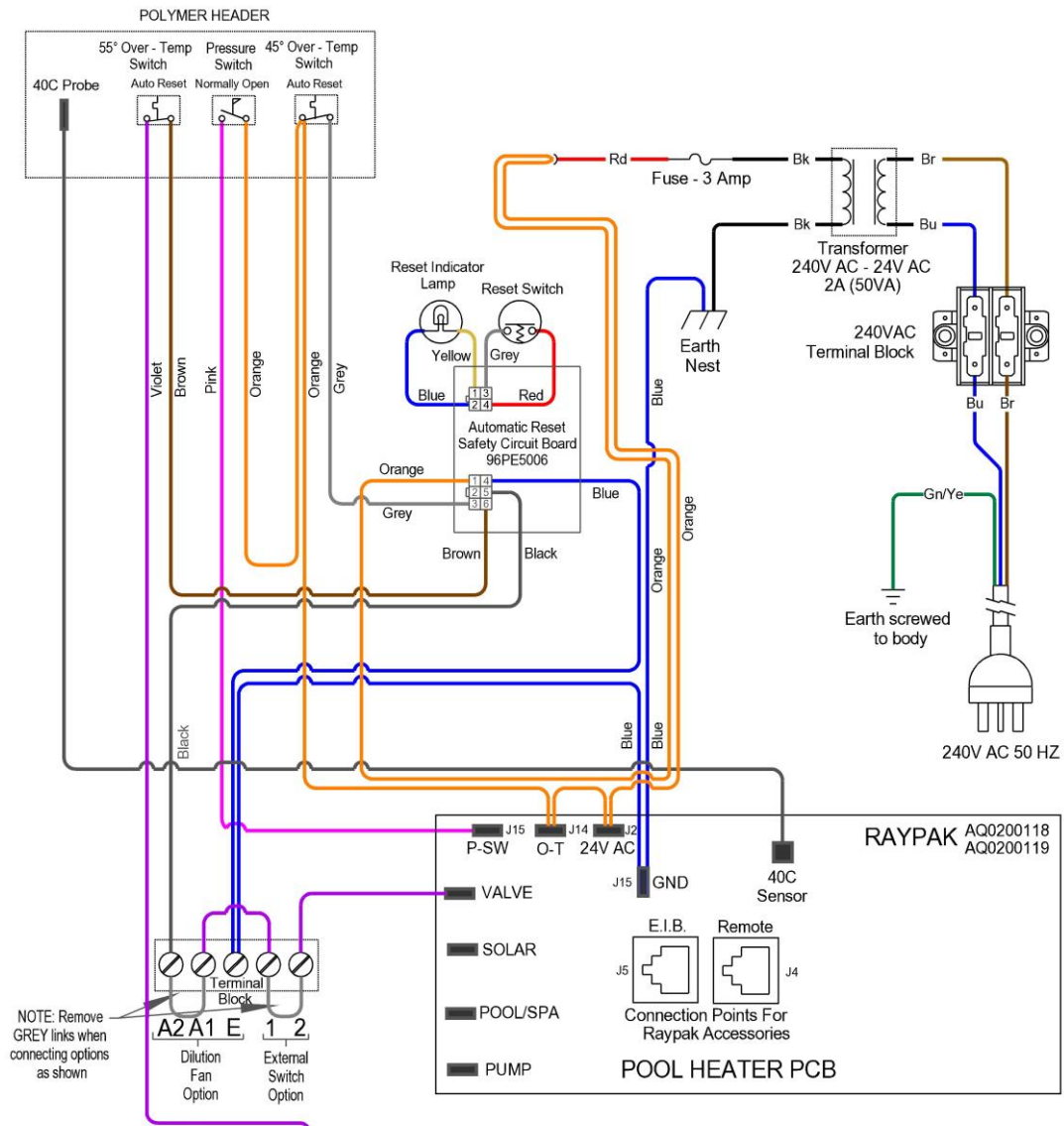

AQ0200304-D WIRING DIAGRAM POOL HEATER MODELS 200 TO 430

Wire Loom Kit - 167 & 200-430 auto reset (P/No: AQ0220320)

Model P0131

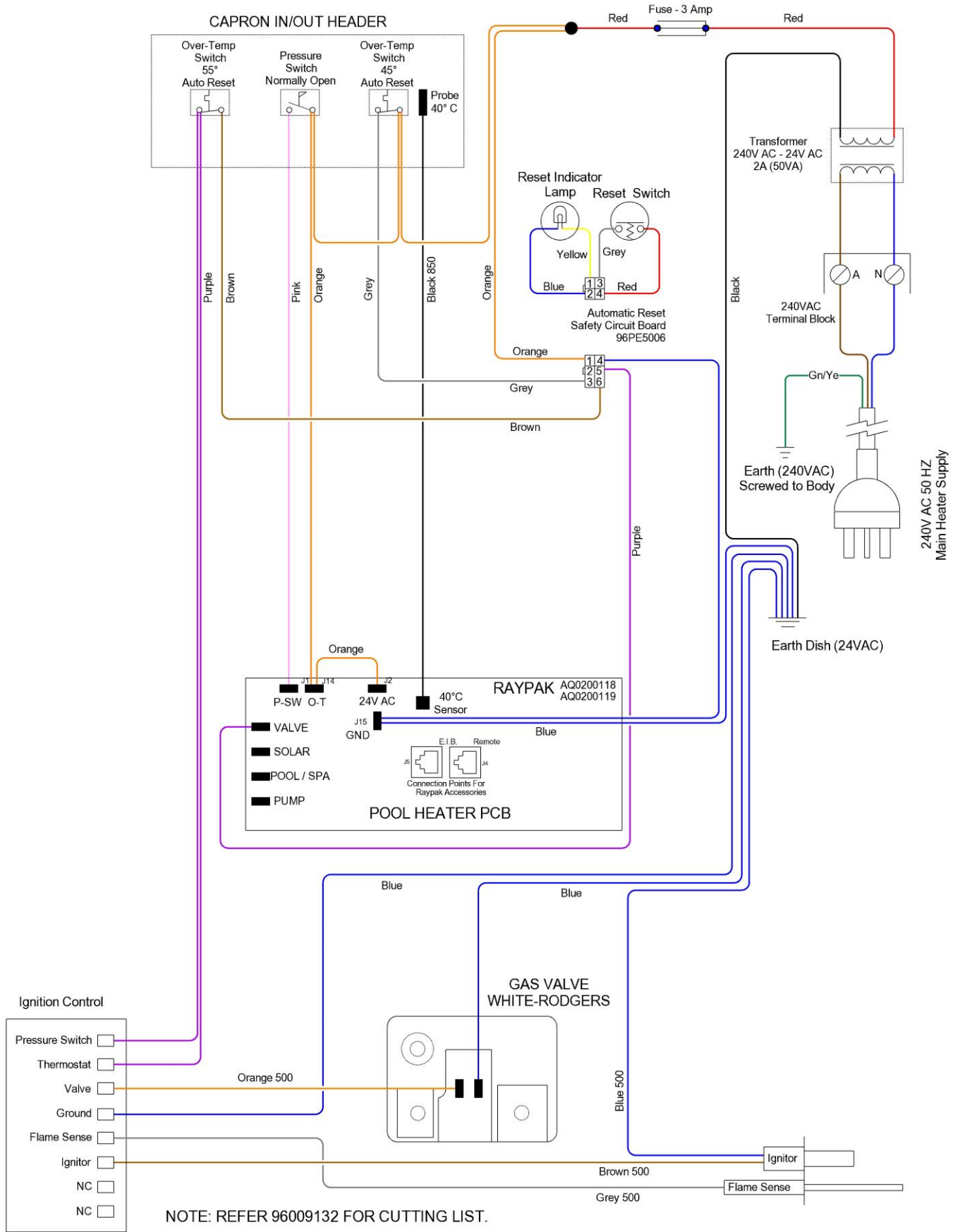

Wire Loom Kit - 131 auto reset (P/No: 96009132)

Model P0127

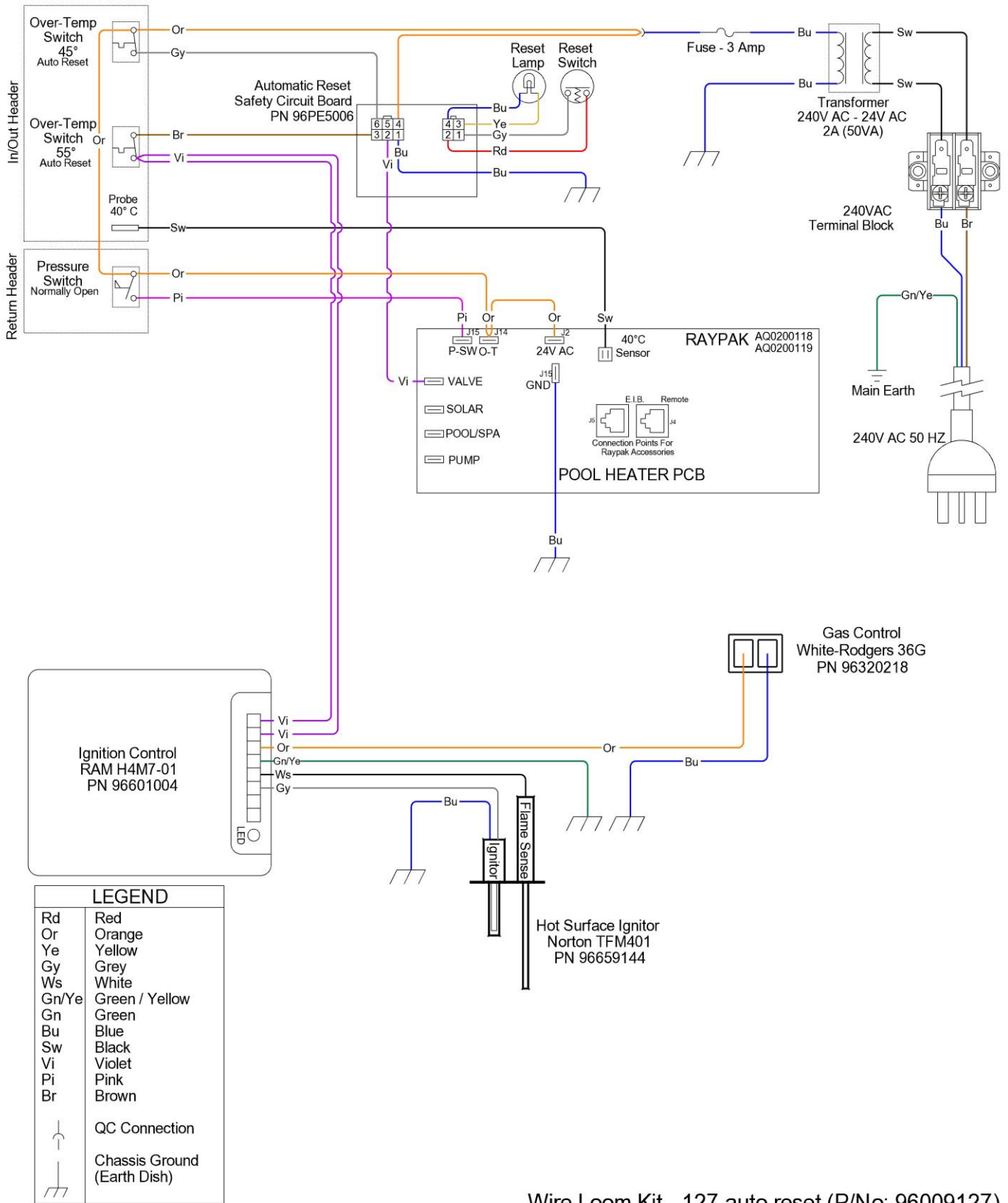

LEGEND	
Rd	Red
Or	Orange
Ye	Yellow
Gy	Grey
Ws	White
Gn/Ye	Green / Yellow
Gn	Green
Bu	Blue
Sw	Black
Vi	Violet
Pi	Pink
Br	Brown
	QC Connection
	Chassis Ground (Earth Dish)

Wire Loom Kit - 127 auto reset (P/No: 96009127)

POOL HEATER OPERATION FLOW CHART

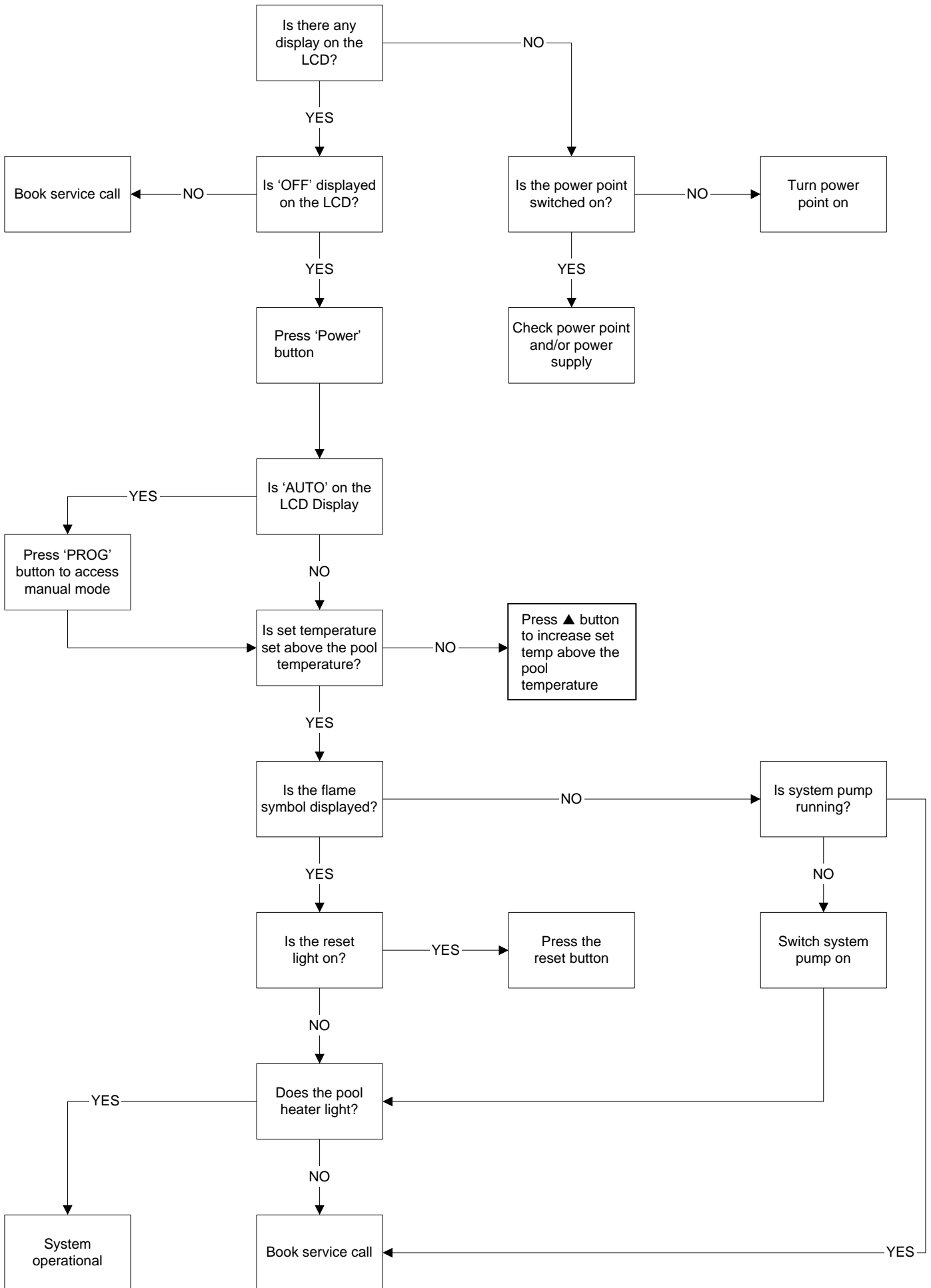

TYPICAL POOL/SPA SYSTEM DIAGRAM

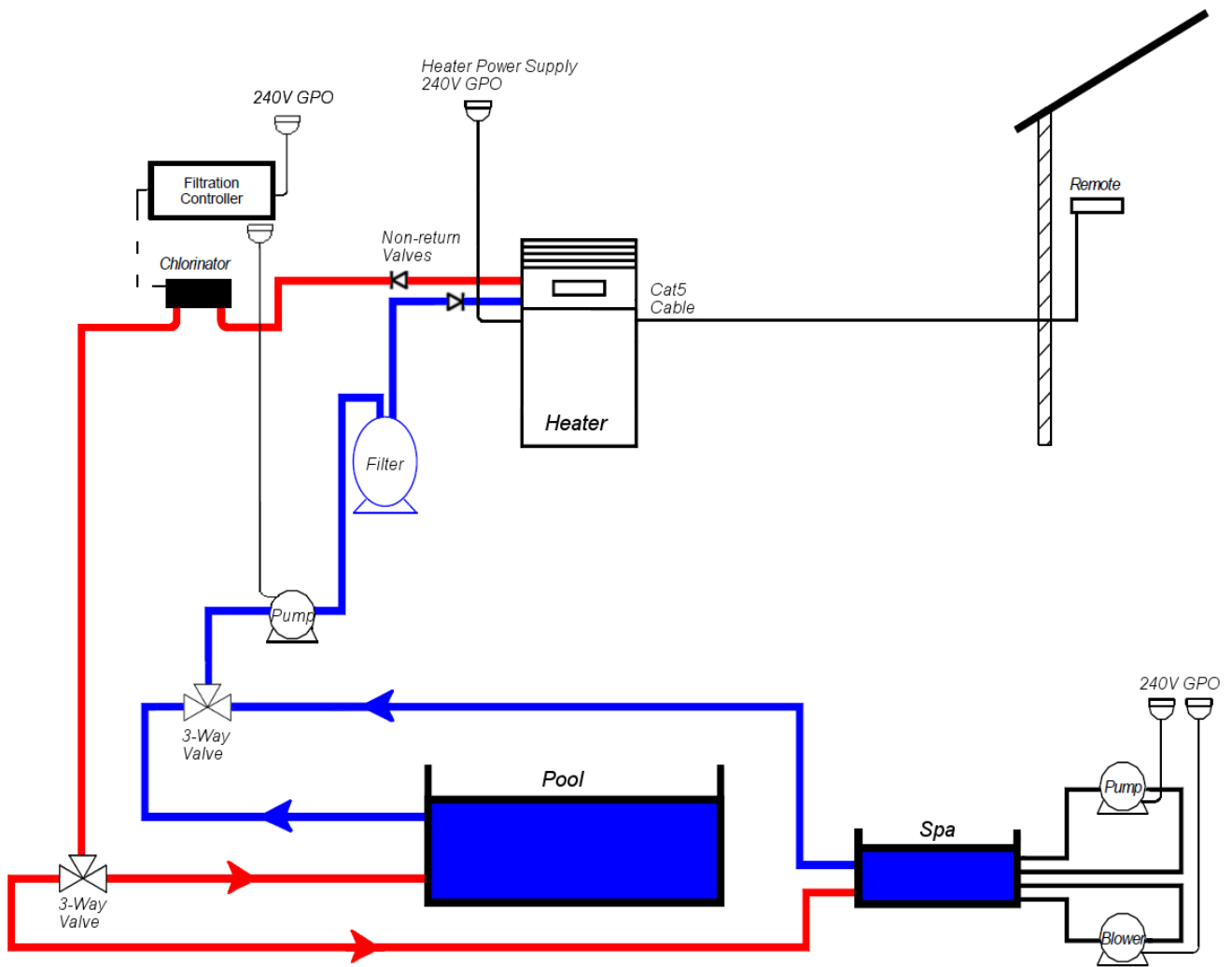

This page is intentionally blank

This page is intentionally blank

This page is intentionally blank

Raypak Pool & Spa Heaters



**Proudly Manufactured by
Rheem Australia Pty Ltd**

RHEEM AUSTRALIA PTY LTD, A.B.N. 21 098 823 511, www.rheem.com.au

RHEEM THERMAL SYSTEMS GROUP PTY LTD, A.B.N. 65 078 743 414, www.rheemthermal.com.au

For Service Telephone 131 031 AUSTRALIA or 0800 657 335 NEW ZEALAND, service@rheem.com.au

For Spare Parts Telephone 1800 812 916, <http://www.rheem.com.au/Spares>

NOTE: Every care has been taken to ensure accuracy in preparation of this publication. No liability can be accepted for any consequences, which may arise as a result of its application.

Revision Date: 19/08/2019

AM190702

96131430-M