

UF 80 ULTRA FINE FILTER

- ✓ Filters down to 3 micron – 1/10th the particle size of sand or glass media filters
- ✓ High strength long lasting filter tank and internals
- ✓ High capacity reduces cleaning and renewal
- ✓ Oil filled pressure gauge for accurate pressure reading
- ✓ Choice of two outlet ports to simplify installation and plumbing



UF 80 ULTRA FINE FILTER



The AstralPool UF Ultra Fine Element filter is designed to filter the smallest particles and debris for sparkling clean pools and spas. Utilising Perlite (which is simply added to the skimmer while the pump is operating) coats the four large capacity filter elements to catch and filter invisible debris and even algae as small as 3 microns in size. Ultra Fine filtration reduces the amount of chemicals required to keep you pool sparkling and healthy.



REVOLUTIONARY PERLITE

With less plumbing and no backwash line, installing and maintaining your AstralPool UF Filter is so simple. Simply hose off elements to remove used Perlite and debris, and add new perlite to the skimmer when the pump is operating. Ideal for pools and spas with high bather loads or high levels of dust and debris, the AstralPool UF filter will make your pool water sparkle and removes particles 1/10th the size of a sand or glass media filter.



EASIER MAINTENANCE

Cleaner water reduces the amount of chlorine and other chemicals required. The simple cleaning procedure avoids back washing in conventional sand filters and saves up to 12,000 litres (3170 US gallons) of water a year, further reducing the

cost of chemicals and saves wasting heated water. An inbuilt automatic air bleed system simplifies your routine maintenance program.



BUILT TO LAST

The AstralPool UF 80 Ultra Fine Filter is made from high quality components. The injection moulded design is made of non corrosive materials and provides ready access to all the elements. Fine tolerance manufacturing increases the life and reliability of the filter.



WARRANTY

Please visit www.astralpool.com.au for full warranty details.

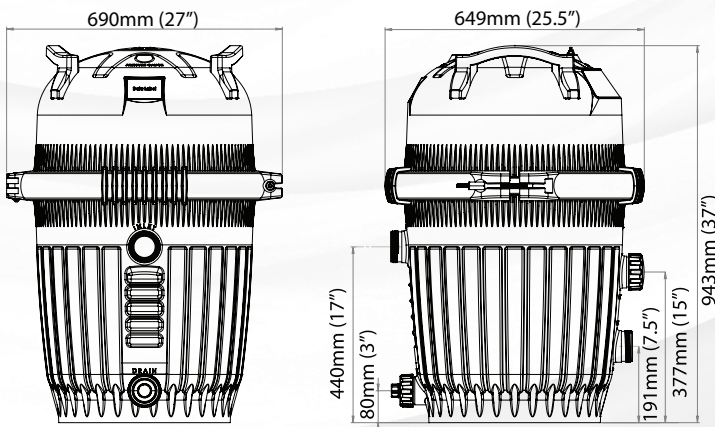

Turnover Capacity for Residential Pools

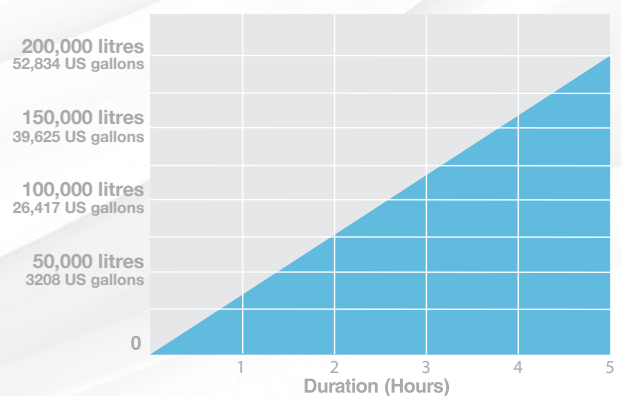

SPECIFICATIONS

Model	Filter Area	Max Flow	Weight
AstralPool UF 80	7.4 m ² / 80 US ft ²	500 lpm/135 US gpm	40 kg/88 lbs



sales@astralpool.com.au

www.astralpool.com.au

[facebook.com/astralpoolAU](https://www.facebook.com/astralpoolAU)