



HAYWARD®

ENERGYLINE INVERTER SERIES



SWIMMING POOL/SPA HEAT PUMP UNIT

Installation & Operation Manual

To prevent potential injury and to avoid unnecessary service calls, read this manual carefully and completely. Retain and ensure this manual is passed on to the end user.

PLEASE KEEP THIS MANUAL FOR FUTURE REFERENCE

Hayward Pool Products (Australia) Pty Ltd.

Melbourne-Sydney-Brisbane-Perth

Email: sales@hayward-pool.com.au | Website: www.hayward-pool.com.au

PO Box 4384 | Dandenong South VIC 3164

ABN 66 083 413 414

Sales Contact Ph: 1300POOLS1 Fax: 1300POOLS2

USE ONLY HAYWARD® GENUINE REPLACEMENT PARTS

IMPORTANT SAFETY INSTRUCTIONS

Before installing or servicing this electrical equipment, turn OFF and ISOLATE power supply.



⚠ **WARNING** ⚠

Read and follow all instructions in this owner's manual and on the equipment. Failure to follow instructions can cause severe injury and/or death

⚠ **WARNING** – This manual contains important information about the installation, operation, and safe use of this heat pump that must be transferred through to the end user of this product.

⚠ **WARNING** – This product should be installed and serviced ONLY by a qualified professional.

⚠ **WARNING** – All electrical wiring MUST be performed by a qualified electrical contractor, and must conform to Local/State/Federal Government electrical regulations and the Latest Edition AS/NZS 3000 Wiring Rules.

⚠ **WARNING** – This appliance is not intended for use by persons (including children) with reduced physical, sensory or mental capabilities, or lack of experience and knowledge, unless they have been given supervision or instruction concerning use of the appliance by a person responsible for their safety. CHILDREN SHOULD BE SUPERVISED TO ENSURE THAT THEY DO NOT PLAY WITH THE APPLIANCE.

⚠ **CAUTION** – This heater is intended for use on permanently installed swimming pools and may also be used with hot tubs and spas if so marked. Do NOT use with storable pools. A permanently installed pool is constructed in or on the ground or in a building such that it cannot be readily disassembled for storage. A storable pool is constructed so that it is capable of being readily disassembled for storage and reassembled to its original integrity. Though this product is designed for outdoor use, it is strongly advised to protect the electrical components from the weather. Select a well-drained area, one that will not flood when it rains. It requires free circulation of air for proper operation. Do not install in a damp or non-ventilated location.

⚠ **WARNING** – Pool and spa components have a finite life. All components should be inspected frequently and replaced at least every ten years, or if found to be damaged, broken, cracked, missing, or not securely attached.



⚠ **WARNING** – **Risk of Electric Shock.** All electrical wiring must be performed by a qualified electrical contractor, and must conform to Local/State/Federal electrical regulations and the Latest Edition AS/NZ 3000 Wiring Rules. **All electrical circuits must be supplied through a Residual Current Device - RCD (Safety Switch), with a residual operating current not exceeding 30 mA.** Hazardous voltage can shock, burn and cause death or serious property damage.

⚠ **WARNING** – **The power supply to the heat pump must be supplied through an isolator switch located next to the unit** and complying with the Latest Edition of the AS/NZS 3000 Wiring Rules.

⚠ **WARNING** – Hayward recommends that a **Lightning Surge Protector Device (SPD)** is installed on the feed circuit to the heat pump by a qualified electrical contractor in accordance with AS/NZS 3000 Australian Wiring Rules Latest Edition.

⚠ **WARNING** – To reduce the risk of electric shock replace damaged wiring immediately. Locate the power cord so that it cannot be damaged by lawn mowers, hedge trimmers and other equipment.

⚠ **WARNING** – Never operate the circulation system at more than 344 kPa (50 PSI) maximum.

IMPORTANT SAFETY INSTRUCTIONS

Before installing or servicing this electrical equipment, turn OFF and ISOLATE power supply.

 **WARNING – Hazardous Pressure.** Pool and spa water circulation systems operate under hazardous pressure during start-up, normal operation, and after pump shut-off. Stand clear of circulation system equipment during pump start-up. Failure to follow safety and operation instructions could result in violent separation of the pump housing and cover due to pressure in the system. This separation could cause property damage, severe personal injury, or death. Before servicing the pool and spa water circulation system, all system and pump controls must be in the off position and the Filter Manual Air Relief Valve must be in the open position. Before starting the system pump, all valves must be set in a position to allow system water to return back to the pool. Do not change the Filter Control Valve position while the system pump is running. Before starting the system pump, fully open the Filter Manual Air Relief Valve. Do not close the Filter Manual Air Relief valve until all the air is expelled and a steady stream of water is discharged from the valve. All suction and discharge valves **MUST BE OPEN** when starting the circulation system. Failure to do so could result in severe personal injury and/or property damage.



 **WARNING – Separation Hazard.** Failure to follow safety and operation instructions could result in violent separation of pump components. Strainer cover must be properly secured to pump housing with the strainer cover lock ring. Before servicing pool and spa circulation system, all system and pump controls must be in off position and the Filter Manual Air Relief Valve must be in open position. Do not operate pool and spa circulation system if system components are not assembled properly, damaged, or missing. Do not operate pool and spa circulation system unless the Filter Air Relief Valve body is in locked position within the filter upper body. All suction and discharge valves **MUST BE OPEN** when starting the circulation system. Failure to do so could result in severe personal injury and/or property damage.



 **WARNING – Suction Entrapment Hazard.** The force from suction in suction outlets and/or suction outlet covers which are damaged, broken, cracked, missing, or unsecured, can cause severe injury and/or death due to the following entrapment hazards:



Hair Entrapment - Hair can become entangled in suction outlet cover.



Limb Entrapment - A limb inserted into an opening of a suction outlet sump or suction outlet cover that is damaged, broken, cracked, missing, or not securely attached, can result in a mechanical bind or swelling of the limb.



Body Suction Entrapment - A differential pressure applied to a large portion of the body or limbs can result in an entrapment.



Evisceration/Disembowelment - A negative pressure applied directly to the intestines through an unprotected suction outlet sump or suction outlet cover which is damaged, broken, cracked, missing, or unsecured, can result in evisceration/disembowelment.

Mechanical Entrapment - There is potential for jewelry, swimsuits, hair decorations, fingers, toes, or knuckles, to be caught in an opening of a suction outlet cover resulting in mechanical entrapment.

 **WARNING – To Reduce the risk of Entrapment Hazards:**

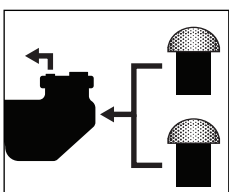

- » When outlets are small enough to be blocked by a person, a minimum of two functioning suction outlets per pump must be installed. Suction outlets in the same plane (i.e. floor or wall), must be installed a minimum of 0.91 metres or three feet (3') apart, as measured from near point to near point to avoid dual blockage by a user.
- » Dual suction fittings shall not be located on seating areas or on the backrest for such seating areas.
- » Never use pool or spa if any suction outlet component is damaged, broken, cracked, missing, or not securely attached.

- » Replace damaged, broken, cracked, missing, or not securely attached suction outlet components immediately.
- » In addition to installing two or more suction outlets per pump, follow all national, state and local government regulations as well as AS 1926.3 Latest Edition.
- » Installation of a vacuum release or vent system, which relieves entrapping suction, is recommended.

CONTENTS

1. INTRODUCTION	5
1.1 Preface	5
1.2 Spa Use Safety Guidelines	6
2. SPECIFICATIONS	7
2.1 Technical data for the swimming pool heat pump unit	7
2.2 Operating Range	8
2.3 Dimensions	8
3. INSTALLATION AND CONNECTION	9
3.1 Functional Diagram	9
3.2 Heat Pump Unit	9
3.3 Hydraulic Connection	10
3.4 Electrical Connection	10
3.5 Initial Start-up	11
3.6 Water Flow Setting	12
4. USER INTERFACE	13
4.1 General Presentation	13
4.2 Setting the Date and Time	14
4.3 Timer Function Settings	15
4.4 Setting the Set Point	16
4.5 Locking and Unlocking the Touch Screen	17
4.6 SILENT Function Settings	18
5. MAINTENANCE AND WINTERISING	19
5.1 Maintenance	19
5.2 Winterising	19
6. TECHNICAL DRAWINGS	20
6.1 Electrical Diagrams	20
6.2 Heating Priority Wiring for a Monophasic Pump	22
6.5 Exploded View and Spare Parts	24
7. TROUBLESHOOTING	31
7.1 Error Codes	31
7.2 Warranty	33

1. INTRODUCTION

1.1 Preface

We thank you for purchasing this Hayward swimming pool heat pump unit. The Energyline INVERTER was designed according to strict manufacturing standards to meet the highest quality requirements. The Energyline INVERTER will offer you exceptional performance throughout the swimming season by adapting its power, electricity consumption and sound level to your swimming pool's heating needs with its INVERTER control logic.

This manual includes all of the necessary information concerning installation, debugging and maintenance. Please attentively read this manual before opening the unit or before carrying out any maintenance operations on it. The manufacturer of this product will not, under any circumstances, be held responsible in the case of injury to the user or damage to the unit resulting from improper installation, debugging or unnecessary maintenance. It is essential to follow all of the instructions specified in the manual at all times.

- » The unit must only be installed by a qualified professional.
- » Repairs must only be made by a qualified professional.
- » All electrical connections must be made by a qualified electrician in accordance with all Local/State/Federal Government electrical regulations and the Latest Edition of the AS/NZS 3000 Wiring Rules.
- » Maintenance and the different operations must be carried out at the recommended times and frequencies as specified in this manual.
- » Only use genuine Hayward spare parts.
- » Failure to comply with these recommendations will void the warranty.
- » This swimming pool/spa heat pump unit heats swimming pool water and maintains a constant temperature; it should not be used for any other purpose.

After having read this manual, keep it for future reference.

This product contains greenhouse effect fluorinated gases covered by the Kyoto protocol.

Type of refrigerant: R32

GWP Value⁽¹⁾: 675, based on the report of the IPCC.

The quantity of refrigerant, based on the F-Gas regulation number 517/2014, is stated on the unit's rating plate.

Periodic inspections for refrigerant leakage can be required as a function of European or local legislation. Please contact your local distributor for additional information.

(1) Global warming potential

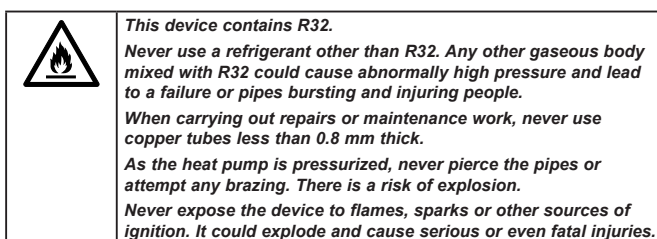

1. INTRODUCTION

1.2 Spa Use Safety Guidelines

⚠️ WARNING– The following “Safety Rules for Hot Tubs” recommended by the U.S. Consumer Product Safety Commission should be observed when using the spa.

- » Spa or hot tub water temperatures should never exceed 40°C [104°F]. A temperature of 38°C [100°F] is considered safe for a healthy adult. Special caution is suggested for young children. Prolonged immersion in hot water can induce hyperthermia.
- » Drinking of alcoholic beverages before or during spa or hot tub use can cause drowsiness, which could lead to unconsciousness and subsequently result in drowning.
- » Pregnant women beware! Soaking in water above 38°C [100°F] can cause fetal damage during the first three months of pregnancy (resulting in the birth of a brain-damaged or deformed child). Pregnant women should adhere to the 38°C [100°F] maximum rule.
- » Before entering the spa or hot tub, users should check the water temperature with an accurate thermometer; spa or hot tub thermostats may err in regulating water temperatures by as much as 2.2°C [4°F].
- » Persons taking medications, which induce drowsiness, such as tranquilisers, antihistamines or anticoagulants, should not use spas or hot tubs.
- » If the pool/spa is used for therapy, it should be done with the advice of a physician. Always stir pool/spa water before entering the pool/spa to mix in any hot surface layer of water that might exceed healthful temperature limits and cause injury. Do not tamper with controls, because scalding can result if safety controls are not in proper working order.
- » Persons with a medical history of heart disease, circulatory problems, diabetes or blood pressure problems should obtain a physicians advice before using spas or hot tubs.
- » Hyperthermia occurs when the internal temperature of the body reaches a level several degrees above normal body temperature of 37°C [98.6°F]. The symptoms of Hyperthermia include: drowsiness, lethargy, dizziness, fainting, and an increase in the internal temperature of the body.

The effects of Hyperthermia include:

- » Unawareness of impending danger.
- » Failure to perceive heat.
- » Failure to recognise the need to leave the spa.
- » Physical inability to exit the spa.
- » Fetal damage in pregnant women.
- » Unconsciousness resulting in danger of drowning.

2. SPECIFICATIONS

2.1 Technical Data for the Swimming Pool Heat Pump Unit

		ENERGYLINE INVERTER SERIES MODELS			
SPECIFICATION TYPE	UNITS	PASRW015H107	PASRW020H109	PASRW030H112	PASRW040H117
* Rated heating capacity	kW	1.62 ~ 7.33	2.18 ~ 8.97	1.97 ~ 11.66	2.90 ~ 17.00
* Electrical power consumption	kW	0.15 ~ 1.17	0.17 ~ 1.54	0.16 ~ 1.99	0.25 ~ 3.12
* COP ^(a)	/	11.04 ~ 6.30	12.77 ~ 5.81	12.57 ~ 5.84	11.08 ~ 5.45
** Rated heating capacity	kW	1.44~ 5.36	1.58 ~ 6.94	1.79~ 8.62	2.80 ~ 13.10
** Electrical power consumption	kW	0.24 ~ 1.14	0.27 ~ 1.53	0.29 ~ 1.90	0.44 ~ 2.97
** COP ^(a)	/	5.98 ~ 4.69	5.82 ~ 4.53	6.17 ~ 4.52	6.40 ~ 4.41
Power supply	V	220V-240V ~50Hz	220V-240V ~50Hz	220V-240V ~50Hz	220V-240V ~50Hz
Max. Power Input	kW	1.48	1.92	2.49	3.8
Max. Input Current	A	6.4	8.4	10.9	16.6
Curve D Circuit Breaker	D	8	10	16	20
Starting Current	A	< maximum continuous current			
Water Flow Rate	ltr/min	52	63	82	122
Water Pressure Drop (max)	kPa	2.3	2.9	6.4	6.7
Hydraulic Connection	mm	50 mm			
Sound Pressure (1m)	dB(A)	40	43	43	46
Sound Pressure (10m)	dB(A)	18	25	25	29
Fan Quantity	/	1			
Fan Speed	RPM	600-800	600-800	850-950	600-850
Refrigerant	/	R32			
Weight of refrigerent	kg	0.35	0.43	0.48	0.65
Unit net dimensions (L/W/H)	mm	1040 / 425 / 615			1130 / 460 / 780
Weight	kg	42	45	46	56



*Outdoor air 27°C - Relative humidity 78% - Incoming water temperature 26°C.

**Outdoor air 15°C - Relative humidity 71% - Incoming water temperature 26°C.

2. SPECIFICATIONS

2.2 Operating Range

Use the swimming pool heat pump unit within the following ranges of temperature and humidity to ensure safe and efficient operation.

	Heating mode 	Cooling mode 
Outside temperature	-7°C – +35°C	+7°C – +43°C
Water temperature	+12°C – +32°C	+8°C – +40°C
Relative humidity	< 80%	< 80%
Setting range from the set point	+15°C – +32°C	+8°C – +32°C

⚠ WARNING – If the temperature or humidity does not correspond to these conditions, the security measures could be activated and the swimming pool heat pump unit may no longer work.

2.3 Dimensions

Models: PASRW015H107/PASRW020H109/PASRW030H112/PASRW040H117

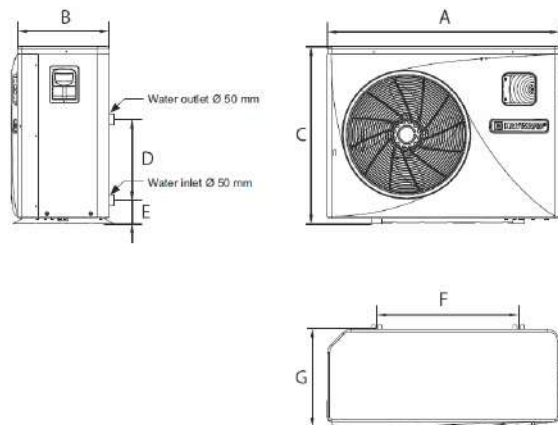

Unit: mm

SIZE \ TYPE	PASRW015H107/PASRW020H109/ PASRW030H112	PASRW040H117
A	956	1002
B	360	4415
C	605	767
D	350	350
E	98	101
F	545	615
G	545	442

3. INSTALLATION AND CONNECTION

3.1 Functional Diagram

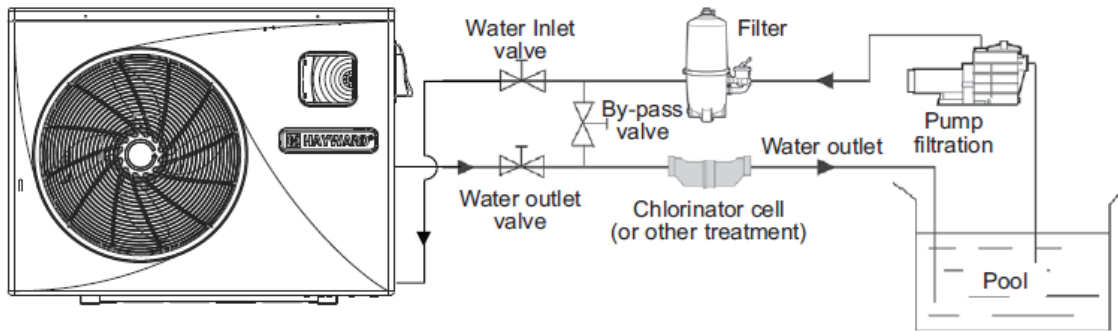

Note: The swimming pool heat pump unit is sold without any treatment or filtration equipment. The components presented in the diagram are spare parts to be supplied by the installer.

3.2 Heat Pump Unit

⚠ WARNING– Place the heat pump outdoors and away from any enclosed technical space.

Placed under a shelter, the minimum required distances shown below must be respected in order to avoid any risk of air recirculation and therefore a deficiency in the unit's overall performance.

- » It is advised to install the unit on a dissociated cement block or a mounting bracket designed for this use and to set up the unit on the supplied rubber bushing (fastenings and washers not supplied).
- » The maximum installation distance between the unit and the swimming pool is 15 metres.
- » The total length of the piping to and from the unit is 30 metres.
- » Insulate both the above ground and buried hydraulic piping.
- » The heat pump must be installed greater than 3.5 m from the edge of the pool in accordance with AS/NZS 3000 Wiring Rules.
- » Do not install the heat pump close to a heat source.
- » For installation in snowy regions we recommend sheltering the unit to avoid snow accumulating on the evaporator.

Unit: mm

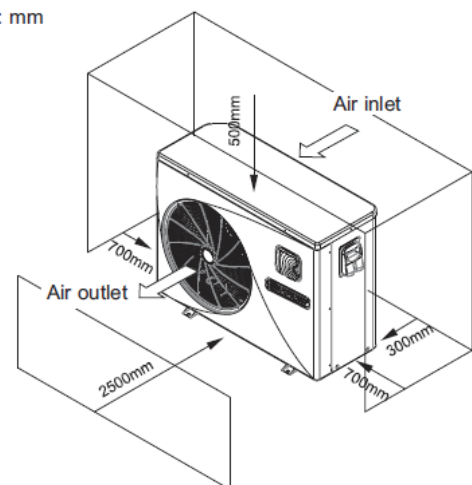

3. INSTALLATION AND CONNECTION

3.3 Hydraulic Connection

The unit is supplied with two 50mm union connections to suit. Connect the water inlet to the heat pump coming from the filter then connect the water outlet to the heat pump at the water conduit going to the pool/spa (see diagram below).

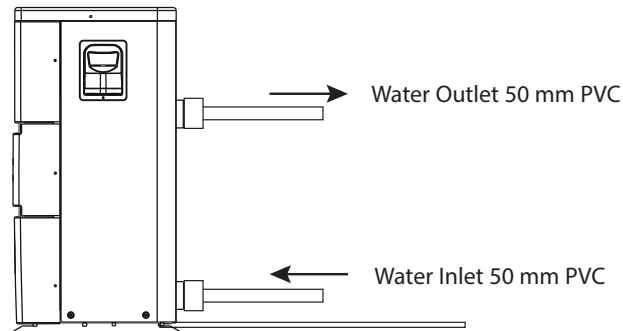

Install a by-pass valve between the heat pump inlet and discharge. Be sure to install the by-pass valve and the supplied union connections at the water inlet and outlet level in order to simplify purging during the winter period and to facilitate access when disassembling for maintenance. If an automatic chemical feeder or a chlorinator cell is used, it should be installed after the heat pump on the discharge line to the pool/spa with the goal of protecting the titanium condenser against an elevated concentration of chemicals.

3.4 Electrical Connection

⚠️ WARNING—Electrical installation and wiring for this equipment must be in conformity with Local/State/Federal Government electrical regulations and must be in accordance with AS/NZS 3000 Latest Edition.

⚠️ WARNING—Always isolate all of the power supplies before commencing any electrical work.

Verify that the available electrical power supply and the network frequency correspond to the required operating current taking into account the appliance's specific location, and the current required to supply any other appliance connected to the same electrical circuit. Ensure that the feed circuit is supplied through a Residual Current Device - RCD with a residual operating current not exceeding 30 mA and an Isolator Switch mounted at the unit.

MODEL	POWER SUPPLY	FREQUENCY	PHASE	CURVE D CIRCUIT BREAKER
PASRW015H107	220 - 240 V	50 HZ	1 N	16 A
PASRW020H109	220 - 240 V	50 HZ	1 N	16 A
PASRW030H112	220 - 240 V	50 HZ	1 N	25 A
PASRW040H117	220 - 240 V	50 HZ	1 N	25 A

⚠️ WARNING—Check that the phases balance does not exceed 2%.

3. INSTALLATION AND CONNECTION

See the corresponding wiring diagram in the appendix. The connection box is located on the right side of the unit.

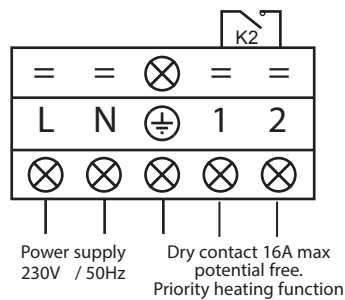

3.5 Initial Start-up

Start-up procedure - After installation is complete, follow these steps:

1. Rotate the fans by hand to verify that they can turn freely by hand, and that the fan is correctly affixed to the motor shaft.
2. Ensure that the unit is connected correctly to the main power supply (see the wiring diagram in the appendix).
3. Activate the filtration/circulation pump.
4. Verify that all water valves are open and that the water flows toward the unit before switching on the heating or cooling mode.
5. Verify that the drainage hose is correctly affixed and that it causes no obstructions.
6. Activate the unit power supply, then press the On/Off button ● on the control panel.
7. Ensure that the alarm signal is not displayed. If necessary see the troubleshooting guide (see § 7.1).
8. Set the water flow using the by-pass valve (see § 3.6 and 2.1), as provided for by each model, to obtain an Entry/Exit temperature of approximately 2°C.
9. After running for several minutes, verify that the air exiting the unit is cool (between 5°C and 10°C).
10. With the unit operating, turn off the filter/circulation pump. The unit should automatically turn off and display error code EO3 (See § 7.1).
11. Allow the unit and the pool pump to run 24 hours per day until the desired water temperature has been reached. When the set point water inlet temperature is reached, the unit will turn off. It will automatically restart (as long as the pool pump is running) if the pool temperature is at least 0.5°C below the set temperature.

Water flow switch

The unit is equipped with a flow switch that turns on the heat pump when the pool filtration pump is running, and deactivates it when the filtration pump is off or not pumping. If the water flow is low, the EO3 alarm code will appear on the display (See § 7.1).

Re-start time delay

The unit is equipped with a time delay of 3 minutes in order to protect the control circuit components, to eliminate restart cycling and contactor chatter. Thanks to this time delay, the unit automatically restarts approximately 3 minutes after each control circuit interruption. Even a brief power interruption will activate the restart time delay.

3. INSTALLATION AND CONNECTION

3.6 Water Flow Setting

With the water entry and exit valves being open, adjust the by-pass valve in order to obtain a difference of approximately 2°C between the inflow and outflow temperature (see principle diagram § 3.1). You can verify the switch by seeing the entry/exit temperatures directly on the control panel.



Note that:

Opening the by-pass valve creates a weaker flow, which leads to an increase in temperature difference.
Closing the by-pass valve creates a stronger flow, which leads to a decrease in temperature difference.

4. USER INTERFACE

4.1 General Presentation

The heat pump is equipped with a digital control panel with a colour touch screen, electronically connected and pre-set at the factory in heating mode.



LEGEND

1	Water Input temperature	8	On/Off/Back	15	Set date and time
2	Defrost mode	9	Setpoint temperature	16	Set On/Off timers
3	Operating mode	10	Hour	17	Access Advanced settings
4	Compressor's ON indicator	11	Operating mode selection	18	Access list of faults
5	Lock screen	12	Adjust setpoint	19	Back (changes not confirmed)
6	Alarm	13	Setting silence mode timer	20	Confirm
7	Water Output temperature	14	Activate silence mode		

OFF Mode

When the heating pump is idle (in standby mode), OFF is displayed as shown on the screen.

ON Mode

When the heating pump is running or priming (setpoint reached), the screen turns blue.

4. USER INTERFACE

4.2 Setting the Date and Time



The date and time can be set in "OFF" mode or "ON" mode

1. Swipe across the main screen.
2. Select the Time Setting.
3. Select the Day, Month and Year.
4. Press the arrow to proceed.
5. Select the time.
6. Press "OK" to save the time and date.
7. Press the  button one time to return to the main screen.

4. USER INTERFACE

4.3 Timer Function Settings

Setting this function is necessary if you would like to run the heat pump for a shorter period than what is defined by the filtration clock. Therefore, you can program a deferred start and an anticipated stop or simply stop a certain time frame from running (at night, for example). It is possible to set one Start Timer and one Stop Timer.



Highlighting:
 Blue = Activated Grey = Deactivated

The timer switch is governed by hour intervals.

Press the button twice to return to the main screen.

4. USER INTERFACE

4.4 Setting the Set Point



In Mode "OFF" or Mode "ON"

1. Swipe across the main screen.
2. Select the Temp Setting.
3. Select the desired temperature.
4. Press "OK" to save the desired temperature.
5. Press the  button to return to the main screen.

 The setting is made with a precision of 0.5 °C.

 It is recommended to never exceed 30°C to avoid alteration of the liners.

4. USER INTERFACE

4.5 Locking and Unlocking the Touch Screen



The screen can be locked or unlocked in either "OFF" mode or "ON" mode

To lock or unlock the screen, hold the  button down for 5 seconds. When the screen lock is activated the lock symbol will be present

4. USER INTERFACE

4.6 SILENT Function Settings

Silence mode enables the heat pump to be used in economic and very silent mode when the heating needs are low (maintaining the pool temperature or need for ultra-silent operation). This function can be Activated/Deactivated manually or using a Timer.

ACTIVATING/DEACTIVATING SILENCE MODE



Silent mode deactivated

Press the button to return to the main screen.

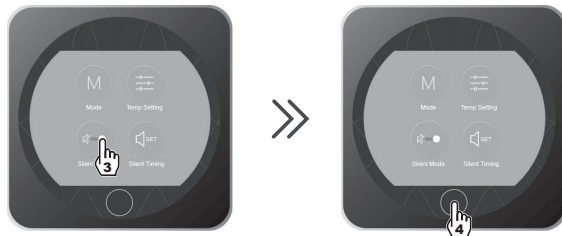

Silent mode activated

SETTING THE TIMER



Press the button twice to return to the main screen.

The timer switch is governed by hour intervals. Once the Timer is activated, it is active 7 days a week

Due to the limitation of the working characteristics of the capacitive touch screen, if there is an interference source from the environment or power supply, please make sure the frequency band of the interference source is outside the range of 100kHz~200kHz, otherwise it will effect the touch function. The display operating tempereature range is from -20°C~70°C.

5. MAINTENANCE AND WINTERISING

5.1 Maintenance

These maintenance operations must be carried out by a professional once per year in order to guarantee the longevity and the good working condition of the heat pump.

- » Clean the coil with the help of a soft brush or jet of air or water (**Warning, never use a high pressure cleaner**).
- » Verify that the drains flow well.
- » Verify the tightening of the hydraulic and electrical connections.
- » Verify there are no leaks from the condenser.
- » Have the unit checked for refrigeration leaks by an **accredited professional**.

⚠ WARNING– Before any maintenance operation, the heat pump must be isolated from all electrical supplies. The maintenance operations must only be carried out by an accredited qualified professional that is authorised to handle liquid refrigerants.

5.2 Winterising

- » Put the heat pump in “OFF” mode.
- » Turn off the power supply to the heat pump.
- » Empty the condenser with the help of the drain to avoid any risk of deterioration (high risk of freezing then cracking).
- » Close the by-pass valve and unscrew the entry/exit connection unions.
- » Eliminate the maximum amount of residual stagnant water from the condenser with the help of an air gun.
- » Close the water entry and exit areas of the heating pump to avoid introducing foreign bodies.
- » Cover the heating pump with a dedicated winterising cover.

⚠ WARNING– Any damage caused by poor winterising maintenance will void the warranty.

6. TECHNICAL DRAWINGS

6.1 Electrical Diagrams

PASRW015H107 / PASRW020H109 / PASRW030H112

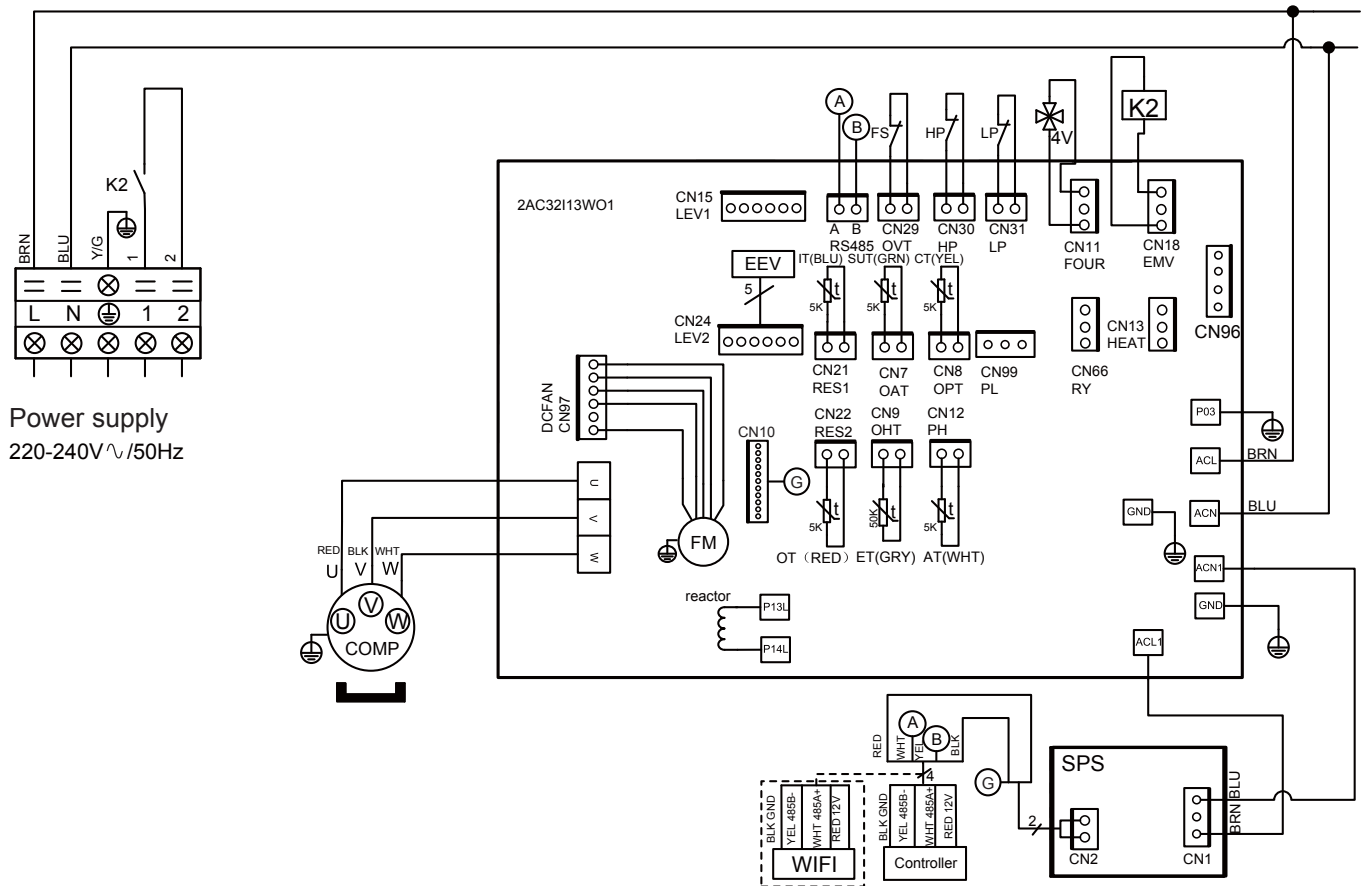

REMARKS

- AT : AIR TEMPERATURE SENSOR
- COMP : COMPRESSOR
- CT : EVAPORATOR TEMPERATURE SENSOR
- EEV : ELECTRONIC EXPANSION VALVE
- FM : FAN MOTOR
- FS : WATER FLOW SWITCH
- HP : HIGH PRESSURE SWITCH
- IT : WATER INLET TEMPERATURE SENSOR

- LP : LOW PRESSURE SWITCH
- OT : OUTLET WATER TEMPERATURE SENSOR
- SUT : SUCTION TEMPERATURE SENSOR
- 4V : 4 WAYS VALVE
- K2 : DRY CONTACT 16 A MAX
- ET : DISCHARGE TEMPERATURE SENSOR
- OPTION

6. TECHNICAL DRAWINGS

6.1 Electrical Diagrams

PASRW040H117

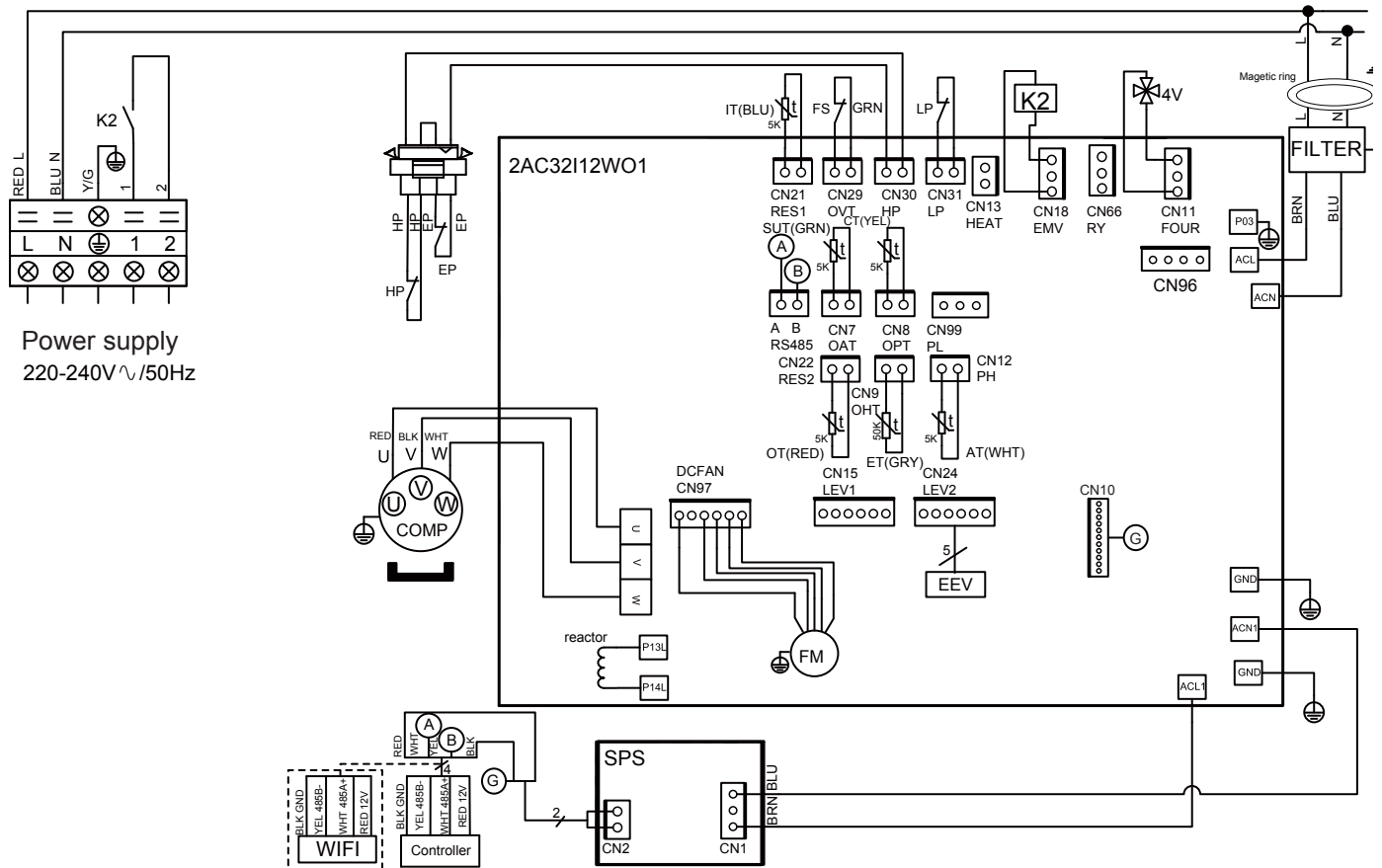

REMARKS

- | | |
|--|---|
| AT : AIR TEMPERATURE SENSOR | LP : LOW PRESSURE SWITCH |
| COMP : COMPRESSOR | OT : OUTLET WATER TEMPERATURE SENSOR |
| CT : EVAPORATOR TEMPERATURE SENSOR | SUT : SUCTION TEMPERATURE SENSOR |
| EEV : ELECTRONIC EXPANSION VALVE | 4V : 4 WAYS VALVE |
| FM : FAN MOTOR | K2 : DRY CONTACT 16 A MAX |
| FS : WATER FLOW SWITCH | ET : DISCHARGE TEMPERATURE SENSOR |
| HP : HIGH PRESSURE SWITCH | OPTION : OPTION |
| IT : WATER INLET TEMPERATURE SENSOR | |

6. TECHNICAL DRAWINGS

6.2 Heating Priority Wiring for a Single Phase Pump

Terminals 1 and 2 deliver a potential-free dry contact, no polarity, rated to 230V 16A max. The Priority Heat Timer is an integral part of the Heat Pump software and will close the potential Free Dry Contact across terminals 1 and 2 when the unit requires the circulation pump to run. After the Heat Pump has reached set-point temperature, it will stop the circulation pump. It will then start the pump every 1 hour and run it for 2 minutes to check the water temperature.

The Hayward Circulation Pump Control Module can be installed by a Pool Professional before the unit is hard-wired and installed by a qualified electrician. Isolate ALL power feeds to the Heat Pump and then connect the Control Wires to terminals 1 and 2 as shown in the diagram below. The polarity of the connection is not important. Alternatively a qualified electrical contractor can connect the control circuit wires for a pump control contactor to terminals 1 and 2 in accordance with AS/NZS 3000 Wiring Rules Latest Edition.

⚠ WARNING— Never connect the power supply of the filtration pump directly to terminals 1 and 2.

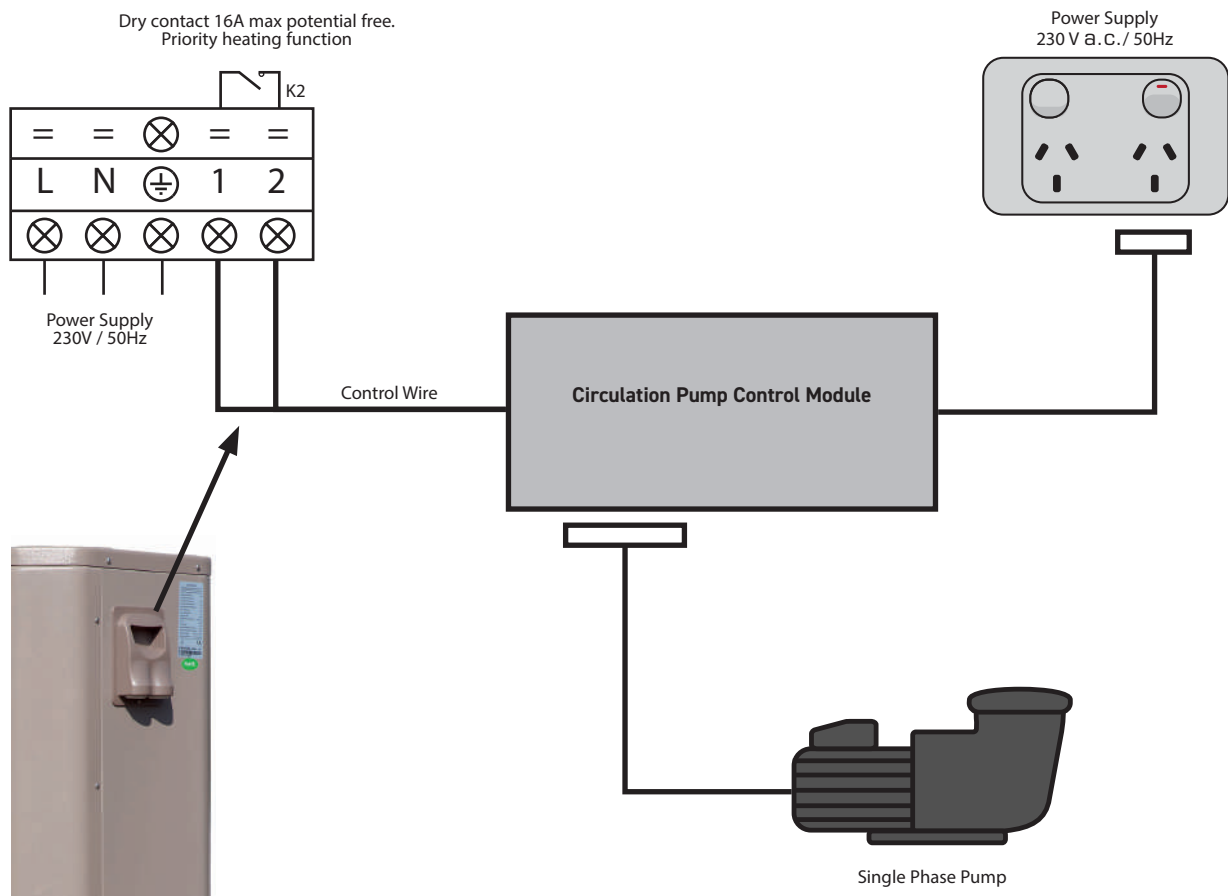

6. TECHNICAL DRAWINGS

6.3 Exploded View and Spare Parts

PASRW015H107

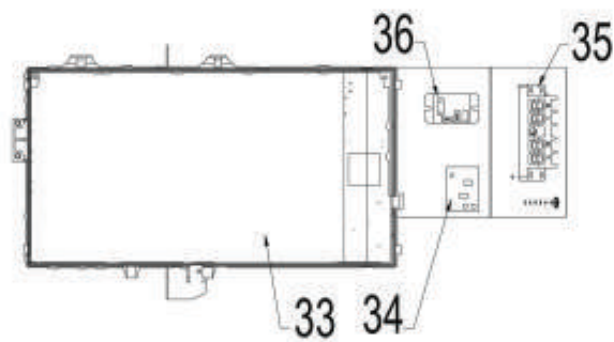
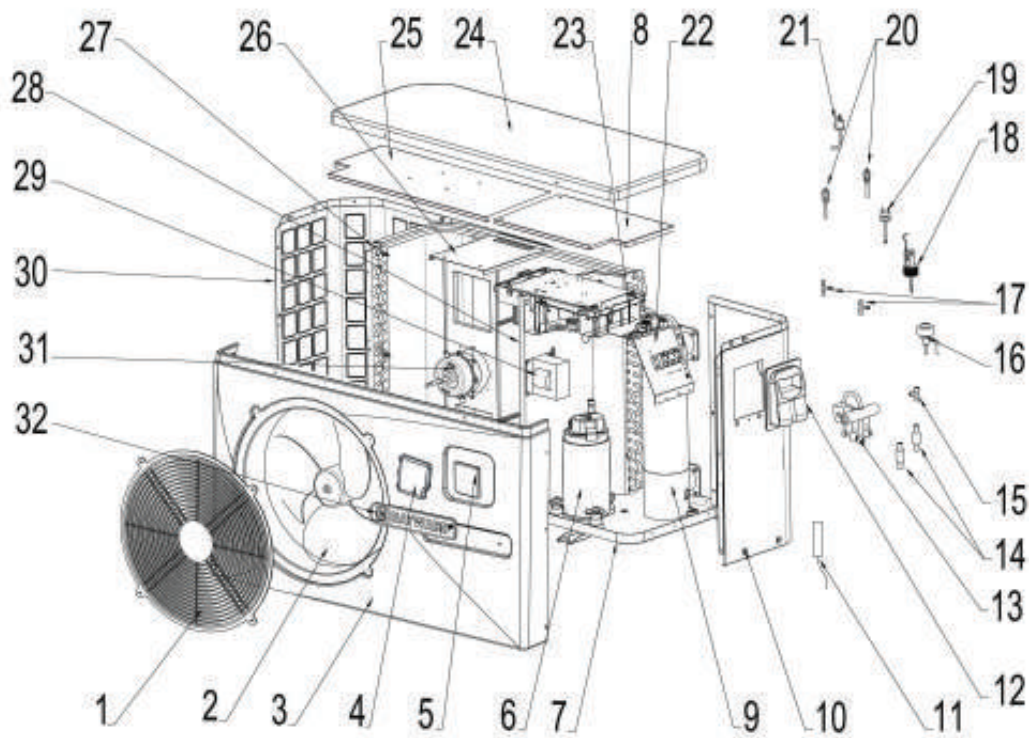

6. TECHNICAL DRAWINGS

6.3 Exploded View and Spare Parts

PASRW015H107

Mark	Ref.	Description	Mark	Ref.	Description
1	HWX20000220245	Fan protection grille	18	HWX83000012	Water Flow Detector
2	HWX301030000006	Fan blade	19	HWX20000360157	Low Pressure Switch NO 0.30MPa/0.15MPa
3	HWX80900160	Front panel	20	HWX20000140150	Pressure Tap 40mm 1/2"
4	HWX80900319	Smoke protection cover	21	HWX20013605	High Pressure Switch NC 3.2MPa/4.4MPa
5	HWX82300038	LED Controller	22	/	/
6	HWX20000110448	Compressor	23	/	/
7	/	/	24	HWX80900055	Top Cover
8	/	/	25	/	/
9	HWX80600037	Titanium/PVC Condensor	26	HWX80700218	Motor Bracket
10	HWX80700453	Right Panel	27	HWX301060202502	Fin Coil
11	HWX83000044	Compressor aspiration sensor 5k-560mm	28	/	/
	/	/	29	HWX82500006	20A 50Hz 5.2mH Coil
	HWX83000049	Ambient Temperature Sensor 5k-350mm	30	HWX80700452	Left Panel
	HWX83000050	Water Outlet Sensor 5k-410mm	31	HWX80200018	DC Ventilator Motor
	HWX83000052	Water Inlet Sensor 5k-850mm	32	HWX20000230596	HAYWARD Logo
	HWX83000026	Compressor Discharge Probe 50k-660mm	33	HWX82300052	Printed Circuit Board Driver
	HWX83000051	De-icing Sensor 5k-680mm	34	HWX82600008	Transformer
	/	/	35	HWX40003901	Terminal Block
12	HWX32009-220029	Access Hatch	36	HWX20000360297	K2 Relay
13	HWX20041437	4 Way Valve			
14	HWX20000140178	Filter Ø9.7 - Ø9.7 (Ø19)			
15	HWX30403000000002	T Connector Ø9.52-2 x Ø6.35 (T) x 1.0			
16	HWX20000140570	Electronic Expansion Valve			
17	HWX20001460	T Connector Ø6.5-2 x Ø6.5 (T) x 0.75			

6. TECHNICAL DRAWINGS

6.3 Exploded View and Spare Parts

PASRW020H109

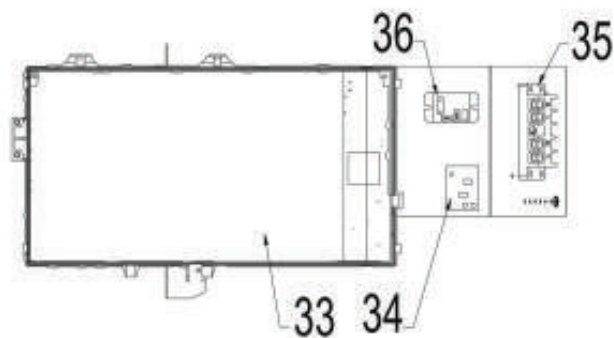
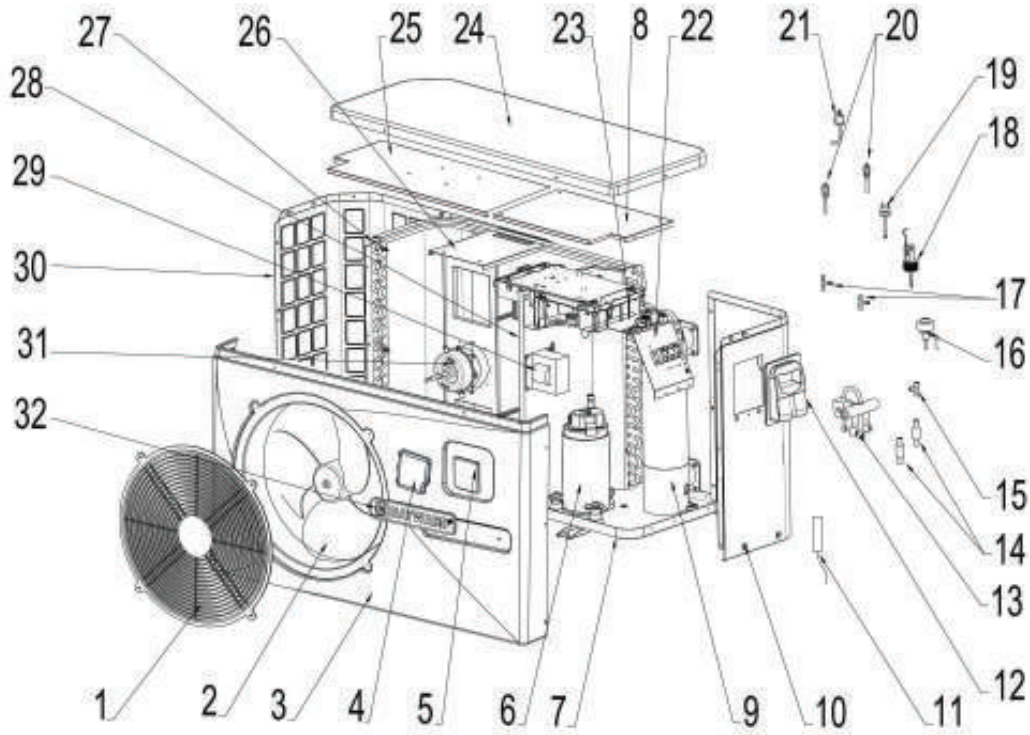

6. TECHNICAL DRAWINGS

6.3 Exploded View and Spare Parts

PASEW020H109

Mark	Ref.	Description	Mark	Ref.	Description
1	HWX20000220245	Fan protection grille	18	HWX83000012	Water Flow Detector
2	HWX301030000006	Fan blade	19	HWX20000360157	Low Pressure Switch NO 0.30MPa/0.15MPa
3	HWX80900160	Front panel	20	HWX20000140150	Pressure Tap 40mm 1/2"
4	HWX80900319	Smoke protection cover	21	HWX20013605	High Pressure Switch NC 3.2MPa/4.4MPa
5	HWX82300038	LED Controller	22	/	/
6	HWX20000110448	Compressor	23	/	/
7	/	/	24	HWX80900055	Top Cover
8	/	/	25	/	/
9	HWX32012120061	Titanium/PVC Condensor	26	HWX80700218	Motor Bracket
10	HWX80700453	Right Panel	27	HWX80600042	Fin Coil
11	HWX83000044	Compressor aspiration sensor 5k-560mm	28	/	/
	/	/	29	HWX82500006	20A 50Hz 5.2mH Coil
	HWX83000049	Ambient Temperature Sensor 5k-350mm	30	HWX80700452	Left Panel
	HWX83000050	Water Outlet Sensor 5k-410mm	31	HWX80200018	DC Ventilator Motor
	HWX83000052	Water Inlet Sensor 5k-850mm	32	HWX20000230596	HAYWARD Logo
	HWX83000026	Compressor Discharge Probe 50k-660mm	33	HWX82300052	Printed Circuit Board Driver
	HWX83000051	De-icing Sensor 5k-680mm	34	HWX82600008	Transformer
	/	/	35	HWX40003901	Terminal Block
12	HWX32009-220029	Access Hatch	36	HWX20000360297	K2 Relay
13	HWX20041437	4 Way Valve			
14	HWX20000140178	Filter Ø9.7 - Ø9.7 (Ø19)			
15	HWX30403000000002	T Connector Ø9.52-2 x Ø6.35 (T) x 1.0			
16	HWX20000140570	Electronic Expansion Valve			
17	HWX20001460	T Connector Ø6.5-2 x Ø6.5 (T) x 0.75			

6. TECHNICAL DRAWINGS

6.3 Exploded View and Spare Parts

PASRW030H112

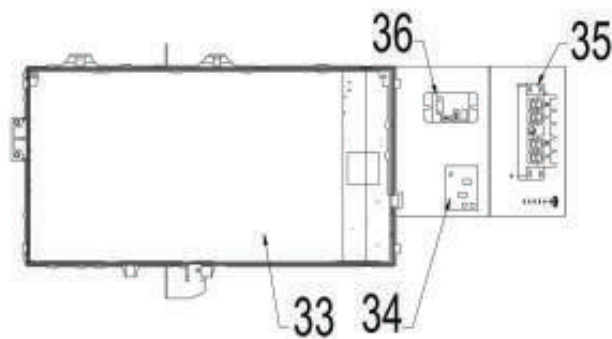
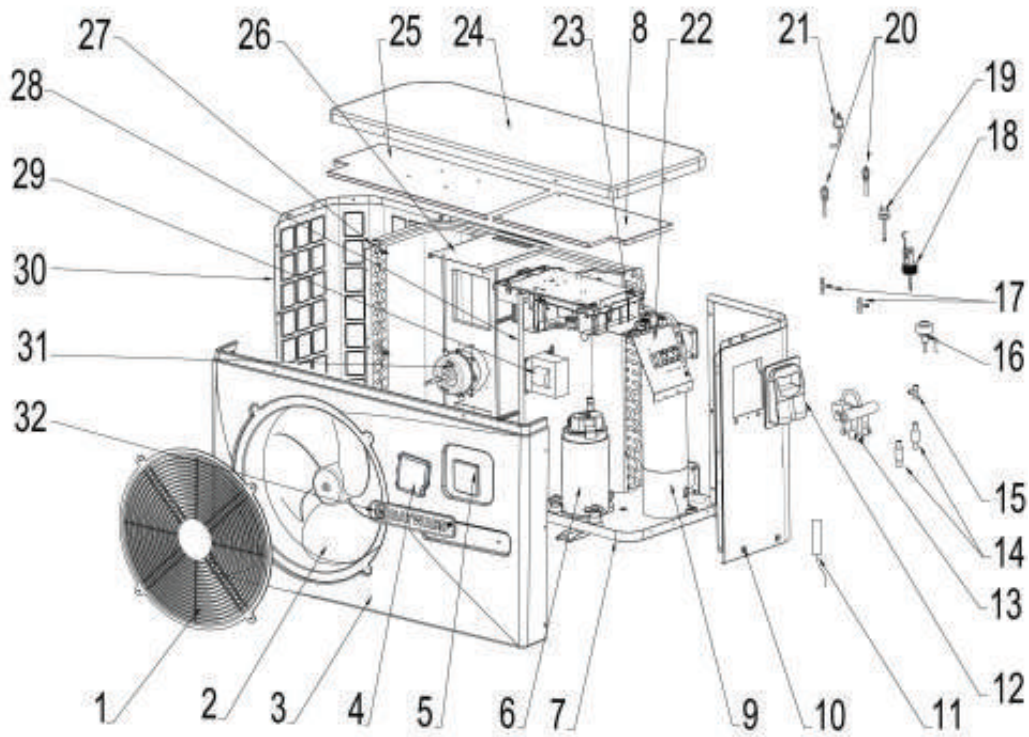

6. TECHNICAL DRAWINGS

6.3 Exploded View and Spare Parts

PASRW030H112

Mark	Ref.	Description	Mark	Ref.	Description
1	HWX20000220245	Fan protection grille	18	HWX83000012	Water Flow Detector
2	HWX3010300000006	Fan blade	19	HWX20000360157	Low Pressure Switch NO 0.30MPa/0.15MPa
3	HWX80900160	Front panel	20	HWX20000140150	Pressure Tap 40mm 1/2"
4	HWX80900319	Smoke protection cover	21	HWX20013605	High Pressure Switch NC 3.2MPa/4.4MPa
5	HWX82300038	LED Controller	22	/	/
6	HWX20000110448	Compressor	23	/	/
7	/	/	24	HWX80900055	Top Cover
8	/	/	25	/	/
9	HWX32012120056	Titanium/PVC Condensor	26	HWX80700218	Motor Bracket
10	HWX80700453	Right Panel	27	HWX80600043	Fin Coil
11	HWX83000044	Compressor aspiration sensor 5k-560mm	28	/	/
	/	/	29	HWX82500006	20A 50Hz 5.2mH Coil
	HWX83000049	Ambient Temperature Sensor 5k-350mm	30	HWX80700452	Left Panel
	HWX83000050	Water Outlet Sensor 5k-410mm	31	HWX80200018	DC Ventilator Motor
	HWX83000052	Water Inlet Sensor 5k-850mm	32	HWX20000230596	HAYWARD Logo
	HWX83000026	Compressor Discharge Probe 50k-660mm	33	HWX82300052	Printed Circuit Board Driver
	HWX83000051	De-icing Sensor 5k-680mm	34	HWX82600008	Transformer
	/	/	35	HWX40003901	Terminal Block
12	HWX32009-220029	Access Hatch	36	HWX20000360297	K2 Relay
13	HWX20041437	4 Way Valve			
14	HWX20000140178	Filter Ø9.7 - Ø9.7 (Ø19)			
15	HWX3040300000002	T Connector Ø9.52-2 x Ø6.35 (T) x 1.0			
16	HWX20000140570	Electronic Expansion Valve			
17	HWX20001460	T Connector Ø6.5-2 x Ø6.5 (T) x 0.75			

6. TECHNICAL DRAWINGS

6.3 Exploded View and Spare Parts

PASRW040H117

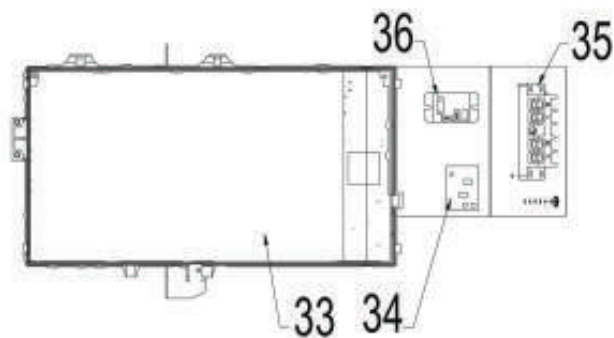
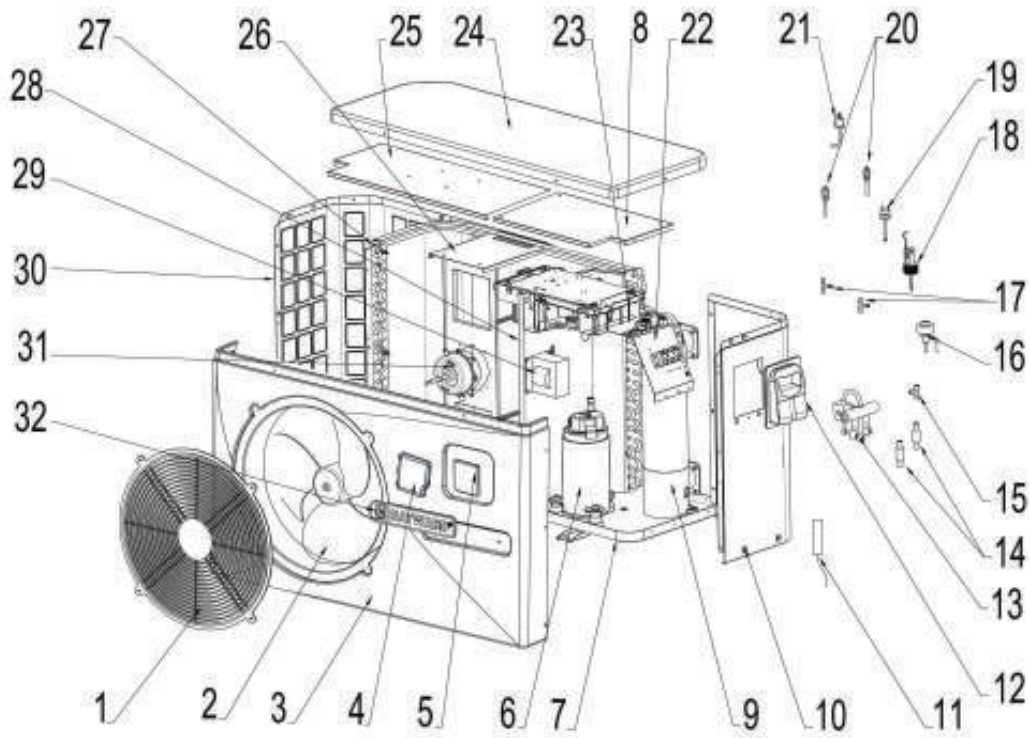

6. TECHNICAL DRAWINGS

6.3 Exploded View and Spare Parts

PASRW040H117

Mark	Ref.	Description	Mark	Ref.	Description
1	HWX20000220369	Fan protection grille	18	HWX83000012	Water Flow Detector
2	HWX3010300000001	Fan blade	19	HWX20000360157	Low Pressure Switch NO 0.30MPa/0.15MPa
3	HWX80900070	Front panel	20	HWX20000140150	Pressure Tap 40mm 1/2"
4	HWX80900319	Smoke protection cover	21	HWX20013605	High Pressure Switch NC 3.2MPa/4.4MPa
5	HWX82300038	LED Controller	22	/	/
6	HWX80100046	Compressor	23	/	/
7	/	/	24	HWX30109020080006	Top Cover
8	/	/	25	/	/
9	HWX80600096	Titanium/PVC Condensor	26	HWX80700248	Motor Bracket
10	HWX80700456	Right Panel	27	HWX80600044	Fin Coil
11	/	/	28	/	/
	HWX83000053	Compressor aspiration sensor 5k-760mm	29	HWX82500005	20A 50Hz 5.2mH Coil
	HWX83000049	Ambient Temperature Sensor 5k-350mm	30	HWX80700455	Left Panel
	HWX83000050	Water Outlet Sensor 5k-410mm	31	HWX20000330132	DC Ventilator Motor
	HWX83000052	Water Inlet Sensor 5k-850mm	32	HWX20000230596	HAYWARD Logo
	HWX83000026	Compressor Discharge Probe 50k-660mm	33	HWX82300007	Printed Circuit Board Driver
	/	/	34	HWX82600008	Transformer
	HWX83000045	De-icing Sensor 5k-1040mm	35	HWX40003901	Terminal Block
12	HWX32009-220029	Access Hatch	36	HWX20000360297	K2 Relay
13	HWX20041437	4 Way Valve			
14	HWX20041444	Filter Ø9.7 - Ø9.7 (Ø28)			
15	HWX3040300000002	T Connector Ø9.52-2 x Ø6.35 (T) x 1.0			
16	HWX81000013	Electronic Expansion Valve			
17	HWX20001460	T Connector Ø6.5-2 x Ø6.5 (T) x 0.75			

7. TROUBLESHOOTING

7.1 Error Codes

If there is a fault on the heat pump, the symbol appears on the screen.

Once the problem has been resolved the error is cancelled automatically and the triangle disappears.

To delete the error list, press on .

Press twice to return to the main screen.



7. TROUBLESHOOTING

7.1 Error Codes

Problem	Error codes	Description	Solution
Water inlet sensor fault	P01	The sensor is open or has short-circuited.	Check the CN21/RES1 connections on the PCB or replace the sensor
Water outlet sensor fault	P02		Check the N22/RES2 connections on the PCB or replace the sensor
Outside temperature sensor fault	P04		Check the CN12/PH connections on the PCB or replace the sensor
De-icing sensor fault	P05		Check the CN8/OPT connections on the PCB or replace the sensor
Compressor aspiration sensor defect	P07		Check the CN71/OAT connections on the PCB or replace the sensor
Compressor discharge sensor fault	P081		Check the CN9/OHT connections on the PCB or replace the sensor
High pressure protection	E01	The sensor is open or has short-circuited.	Check the CN30/HP connections on the card or replace the sensor Check the water flow Check the water flow switch Check the valve opening Check the by-pass Check the finned coil is not clogged Water temperature too hot Incondensable problem after maintenance, empty and evacuate the cooling circuit Refridgerant load too high, remove fluid into a liquid bottle
Low pressure protection	E02	The sensor is open or has short-circuited.	Check the AI/DI03 connections on the card or replace the sensor Large gas leak, search for the leak with the detector Air flow too low, check the ventilator rotation speed Check the Finned Coil is not clogged, clean its surface
Flow sensor fault	E03	The sensor is open or has short-circuited.	Check the AI/DI0 connections on the card or replace the sensor Lack of water, check the filtration pump operation Check the stop valve opening Check the by-pass adjustment
Input/Output temperature difference > 13°C	E06	Applicable in Cooling mode only	Lack of water, check the filtration pump operation Check the stop valve opening Check the by-pass adjustment
Antifreeze protection Cooling mode	E07	Water output temperature < 4°C	Stop the heat pump, empty the condenser risk of freezing
Communication problem	E08	No communication between the parent electronic card and the Inverter card	Check the connections (see electrical diagram)
Level 1 antifreeze protection	E19	2° < Water temperature < 4° and Air temperature < 0°	Stop heat pump operation, empty the condenser to avoid freezing, by default the heat pump starts the filtration pump to avoid icing over
Level 2 antifreeze protection	E29	Water temperature < 2° and Air temperature < 0°	Stop heat pump operation, empty the condenser to avoid freezing, by default the heat pump starts the filtration pump and the heat pump to avoid icing over.
Fan motor fault	F031	Motor jammed or faulty connection	Check free rotation; check CN97/DC connectors; replace the motor
Fan motor fault	F051	Faulty connection	Check the DCFAN/CN97 connector; replace the motor
Exterior temperature too low	TP	Operating limit reached	Stop the heat pump

7. TROUBLESHOOTING

7.2 Warranty

STANDARD CONDITIONS - Australia and New Zealand Hayward Pool Products (Australia) Pty Ltd (ABN 083 413 414) ("Hayward Pool Products (Australia)") distributes Hayward Pool Products in Australia and New Zealand and provides the following warranties:

STATUTORY RIGHTS

1. The benefits to the consumer under this warranty are in addition to other rights and remedies of the consumer under the laws in relation to the goods and services to which the warranty relates; and
2. Our goods come with guarantees that cannot be excluded under the Australian Consumer Law. You may be entitled to a replacement or refund for a major failure and for compensation for any other loss or damage. You are also entitled to have the goods repaired if the goods fail to be of acceptable quality and the failure does not amount to a major failure.

LIMITED WARRANTY

Hayward Pool Products (Australia) warrants that its products are free from defects in materials and manufacture for 12 months from date of supply by Hayward Pool Products (Australia) plus 90 days to allow for installation and supply (unless otherwise specified). Hayward Pool Products (Australia) will at its discretion, except in the circumstances described below, either repair or replace any product proven to be defective during the warranty period for either materials of manufacture or alternatively pay the cost of repair or replacement within 90 days of the receipt of the defective product, barring unforeseen delays.

This warranty is for domestic installation only, is personal to the original purchaser and does not pass to any subsequent purchaser(s).

- To the extent permitted by law, Hayward Pool Products (Australia) will not be liable for products which fail or become defective during the warranty period as a result of freezing, accident, negligence, improper installation, water chemistry, misuse, tampering or lack of care.
- To the extent permitted by law, except as set out in this Warranty, Hayward Pool Products (Australia) excludes all statutory or implied conditions and warranties and any other liability it may have to the Customer (including liability for indirect consequential loss) that may arise under statute or at law including without limitation for breach of contract, in tort (including negligence) or under any other cause of action.
- To the extent permitted by law, except as set out in this Warranty, Hayward Pool Products (Australia) limits its liability under any condition or warranty which cannot be legally excluded in relation to the supply of Goods and Services to:
 1. Repairing the Goods;
 2. Replacing the Goods or supplying equivalent Goods or Services again;
 3. Paying the cost of replacing the Goods or of supplying equivalent Goods or Services again; or
 4. Paying the costs of repairing the Goods.

Claims made for warranty, labour or infield support will not be accepted by Hayward Pool Products unless evidence is provided that installation has been completed in accordance with standard warranty conditions. Please refer to specific program document for details.

WHAT TO DO IF YOU HAVE A WARRANTY CLAIM

Warranty service requests can be faxed to:
Hayward Pool Products (Australia) Pty Ltd.
Fax: 1300 POOLS2 (1300 766571)
Or submitted to your local Hayward Pool Products (Australia)
Branch Office.

The faulty product is to be returned to the place of purchase, or where installed by an approved agent to an authorised warranty agent. No returns will be received directly from end consumers by Hayward Pool Products (Australia). You are responsible for arranging removal of the defective product and arranging installation of the repaired or replacement product, all transportation (and any applicable insurance costs) of transporting the product to the supplier and transporting the replaced or repaired product from the supplier. All returns are subject to Hayward Pool Products (Australia)'s written approval and must be accompanied by either:

1. A Field Inspection Report authorised by the Local Customer Service Manager or Authorised Agent; or

To determine if you are eligible for an extended warranty register your Hayward pool products
online today at:

www.hayward-pool.com.au



Hayward Pool Products (Australia) Pty Ltd.
Melbourne-Sydney-Brisbane-Perth

Email: sales@hayward-pool.com.au | Website: www.hayward-pool.com.au
PO Box 4384 | Dandenong South VIC 3164
ABN 66 083 413 414

Sales Contact Ph: 1300POOLS1 Fax: 1300POOLS2

Code:83900150



Hayward, Energyline Pro, OmniLogic
and AquaRite+ are registered
trademarks of Hayward Industries, Inc.
© 2019 Hayward Industries, Inc.